

SCOPE OF SERVICES FOR THE ESTANCIA BASIN WATERSHED
HEALTH, RESTORATION, AND MONITORING PROJECT

POST-FIRE MONITORING STUDY

DRAFT: July 25, 2008

NOTE: THIS DOCUMENT HAS NOT YET BEEN REVIEWED BY SWCA EDITORS

Prepared for

**THE ESTANCIA BASIN WATERSHED HEALTH,
RESTORATION AND MONITORING COMMITTEE
C/O
CLAUNCH-PINTO SOIL AND WATER CONSERVATION DISTRICT
P.O. Box 129
Mountainair, New Mexico 87036
Telephone (505) 847-2941**

Prepared by

SWCA® ENVIRONMENTAL CONSULTANTS
5647 Jefferson Street NE
Albuquerque, New Mexico 87109
Telephone: (505) 254-1115; Fax: (505) 254-1116

SWCA Project No. 12996
July 25, 2008

TABLE OF CONTENTS

Scope of Services for the Estancia Basin Watershed Health, Restoration, and Monitoring Project ..	1
Task 1 - Literature Review and Plan Development	1
Task 2 - Study Site Locations and Installations	3
Task 3 - Initiate Monitoring Measurements	3
Task 4 - Data Management	4
Task 5 - Reporting to the Estancia Basin Watershed Health, Restoration and Monitoring Steering Committee	4
Literature Review of Fire Monitoring Protocols.....	5
Monitoring Plan	19
Schedule	35
Budget	37
Equipment List.....	37
Approval of Estimate and Notice to Proceed.....	38
References.....	39
Appendix A. Trigo Fire Post-Fire Monitoring Meeting Minutes.	45

SCOPE OF SERVICES FOR THE ESTANCIA BASIN WATERSHED HEALTH, RESTORATION, AND MONITORING PROJECT

In April 2008 a large area of the Estancia Basin watershed was burned in the 13,709 acre Trigo wildfire (Figure 1). This burn area encompassed a large portion of the Cibola National Forest and also included 3,712 acres of private land on its eastern fringe. Fire creates significant impacts to watershed health, which in turn impacts water yield and ground water recharge. Since three large wildfires (Ojo Peak, Trigo and Big Spring) have now burned a considerable portion of the eastern slopes of the Manzano Mountains (Figure 1), the impacts of wildfire on Estancia Basin watershed health are likely significant. SWCA Environmental Consultants are currently monitoring the effects of thinning treatments in the area as part of the Estancia Basin Watershed Health, Restoration and Monitoring Project since 2007. That project is overseen by the Estancia Basin Watershed Health, Restoration and Monitoring Steering Committee (EBWHRMSC), with funding from the New Mexico State Water Trust Board. The EBWHRMSC recently awarded SWCA additional funding to develop and implement post-fire monitoring to evaluate wildfire impacts to Estancia Basin watershed health. SWCA developed this proposed scope of services, task list, study plan, and budget that will investigate the impacts of wildfire on forest and watershed health, and to enhance our knowledge of forest disturbances and their impacts on hydrology of the Estancia Basin. Of the three major wildfires, Ojo Peak, Trigo, and Big Spring, we have chosen to focus efforts on the Trigo. Replicated study sites across watersheds will be more comparable if they are located within an area that burned at about the same time. The Trigo fire also was the largest of the three, it was centrally located within the study region and relative to our existing forest thinning monitoring site, and it burned more watersheds than the other two (Figure 1).

SWCA's proposed tasks, literature review, proposed monitoring plan, proposed budget, and proposed schedule for Estancia Basin post-fire monitoring are provided below.

TASKS

The proposed fire monitoring study is partitioned into five tasks:

Task 1 – Literature Review and Plan Development

SWCA has completed a review of forest fire monitoring literature for hydrology, vegetation, soils and erosion, and wildlife parameters. This review will provide us with information on the most current and best approaches for monitoring appropriate parameters. The results of that literature review are presented below (Literature Review of Fire Monitoring Protocols).

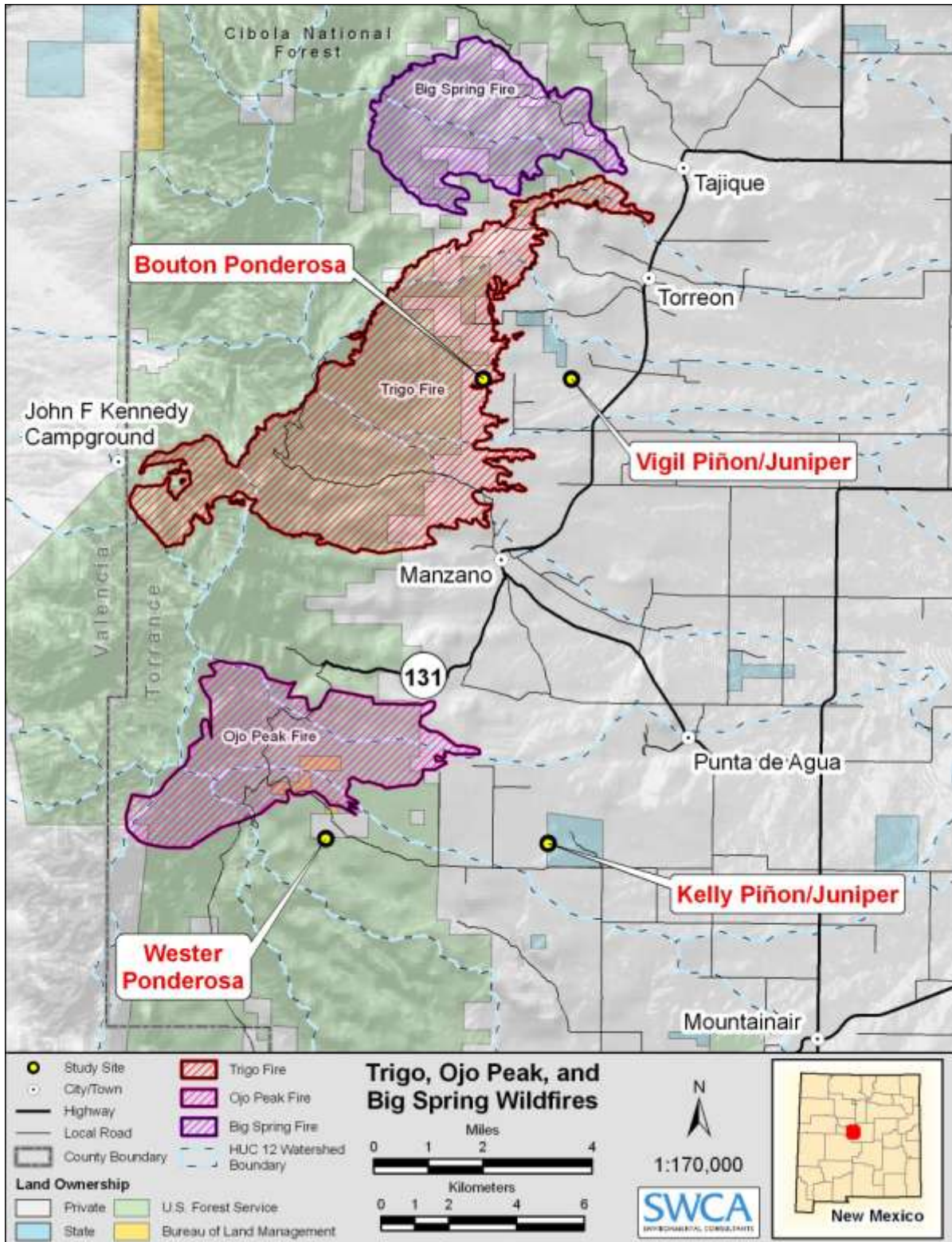

Figure 1. Map of the Manzano Mountains showing the locations of the Ojo Peak, Trigo, and Big Spring wildfire, and existing Estancia Basin Watershed Health, Restoration and Monitoring Project study sites.

This document will serve as the post-fire monitoring plan, and this plan has been developed in accordance with literature findings and also with the guidance of the EBWHRMSC and other specialists in the field. Other monitoring projects being conducted by other agencies are also in progress on the Trigo burn site, and efforts will be made to collaborate with Principal Investigators from each of these projects to extend our span of knowledge and data collection.

A meeting with other organizations (e.g., US Forest Service, USGS, New Mexico State Forestry and the New Mexico Environment Department) conducting or planning post-fire monitoring on the east slopes of the Manzano Mountains, including the Ojo Peak, Trigo, and Big Spring wildfires, was hosted by SWCA on July 16, 2008. The purpose of the meeting was to develop collaborative efforts for post-fire monitoring for environmental conditions, and to develop communications and data sharing across studies. Summary notes for that meeting are attached (Appendix A).

Task 2 – Study Site Locations and Installations

Study site selections will be made in August 2008. Potential landscape areas appropriate for sampling will be determined using GIS overlay technology to overlay and isolate environmental factors of interest (elevation, slope, soil types, vegetation types, burn severity, etc.). Study sites will be located on private land on the eastern fringes of the burn and will be distributed across 4 watersheds in order to enable analysis of burn impacts on a landscape scale.

24 plots will be established across the 4 watersheds (6 plots in each watershed) and will be permanently marked for repeat measurements, initially over a three year period with the available funding. Plots will be located within ponderosa pine stands and stratified by burn severity (as determined by the Burned Area Emergency Response [BAER] team) into low, high and unburned reference areas. Within each of these monitoring plots, hydrologic and soil monitoring will be conducted using the protocols outlined below (Monitoring Parameters, and Metrics).

One of the existing forest thinning monitoring sites (Bouton ponderosa pine) that SWCA had already installed and began measurements of rainfall and runoff in November of 2007, burned in the Trigo fire (Figure 1). One of the paired study plots was intensely burned, and the other was lightly burned. We will continue monitoring that site, but now for post-fire environmental changes, using the same plots, instruments and sampling design and measurements as the rest of the forest thinning monitoring study sites. Data from the Bouton ponderosa site will then be used to compare the intensely burned plot to the lightly burned plot, and compared with the new the post-fire monitoring study proposed below, and also compared to the remaining unburned forest thinning monitoring study sites.

Task 3 – Initiate Monitoring Measurements

Monitoring parameters will include measurements of vegetation, hydrology, soils and wildlife. All monitoring will occur within the plot design or adjacent to the plot.

Hydrological monitoring will also encompass major drainages within or originating from each watershed studied. Measurements will be initiated in September and October of 2008.

Vegetation monitoring parameters will be measured on a bi-annual basis- in the early (May) and late (September) summer, while some soil and wildlife parameters will require monthly data collection and weather and hydrological measurements will occur year round. Three automated wildlife cameras will be erected in each severity type and rotated between the four watersheds on a monthly cycle. The monitoring plan is designed to be carried out over a three year period, with the intention of expanding that period to 10 years, however this will be contingent upon future funding.

Task 4 – Data Management

Data for all parameters will be compiled in a central database managed by SWCA (computer directory and folder system) in MicroSoft Excel format files. Summaries of data will be produced as Excel graphs, and will be produced annually. To ensure data quality, an inspection of the collected data will be performed bi-annually, including visual assessment of data ranges and points for potential errors.

Task 5 – Reporting to the Estancia Basin Watershed Health, Restoration and Monitoring Steering Committee

The data and summary graphs will be provided to the New Mexico Forest and Watershed Restoration Institute (NMFWRI) for public access posting on their web site on an quarterly/annual basis. An annual report will be provided the EBWHRMSC after the end of each calendar year (February of each year), presenting summary graphics, data, and interpretations of the previous year's findings. After each annual report has been approved by the EBWHRMSC, the reports will be submitted to the NMFWRI for posting on their web site. However, for the first year of the project, SWCA will provide the first annual report one year after initiation of monitoring, and then move to the February reporting schedule for subsequent years (see Schedule below).

LITERATURE REVIEW OF FIRE MONITORING PROTOCOLS

INTRODUCTION

Large high severity wildfires are now commonplace in southwestern ecosystems and are associated with a number of significant and undesirable ecological impacts (Covington and Moore 1994; Fule et al. 1997). Following high-intensity crown fires, timber resources are often damaged or destroyed; wildlife habitat is transformed affecting its suitability for some species; soil nutrient stores are depleted; soil hydrology is altered; and duff, litter, and vegetation layers are removed exposing soil to rapid erosion events which in turn overwhelm riparian areas, streams, and rivers (Campbell et al. 1977).

In order to learn from the impacts of recent fires in the southwest, burn monitoring is carried out to inform rehabilitation efforts and future forest management. Choosing and implementing the appropriate monitoring protocols is a critical step in the execution of a fire monitoring program. There are a myriad of monitoring methods which can be employed by fire management professionals. The criteria for method selection includes: complexity of methodology, prospects for long-term consistency, and time and funding available for implementation. Some of the most popular fire monitoring designs used by agencies follow the National Park Service Fire Monitoring protocol and Forest Service Forest Inventory and Analysis (FIA) plot designs. The following provides a review of peer reviewed literature of monitoring protocol that have been utilized in projects similar to the Estancia Basin Watershed Health Post-fire Monitoring Study.

VEGETATION RESPONSE POST FIRE

Many studies have assessed the impact of fire on vegetation response and the time required for reestablishment of native species. Monitoring methods that assess species cover and richness vary. Methods that best measure richness of an area (e.g., timed meander) are limited by a qualitative estimate of species importance and an inability to define other vegetation patterns (Palmer et al. 1995). Likewise, those methods that enable a researcher to quantify the relative importance of each species and other patterns (e.g., systematic plots/ grids) are limited by cost and time to adequately sample enough area for a full flora record (Stohlgren et al. 1998). A sampling design that detects rare species, such as early establishing exotics, but is also capable of defining vegetation patterns and individual species' relative importance is desired.

There are four main monitoring techniques that are readily applied for detecting species abundance and cover; these techniques are- varying intensity-systematic plot, stratified-random plots, modified-Whittaker plots, and timed meander. Huebner (2007) employs all four methods in assessing abundance of invasive species following a burn and provides an evaluation of each.

The systematic-plot method, contained 32 1m² plots arranged along a 200m central transect. Four plots placed at each cardinal direction were arrayed 1m away from a point 15 m on either side of the transect, at 50m intervals along the transect. Percent cover of herbs, shrubs, and vines rooted in the plots, and percent cover and density of

the tree seedlings under 1 m in height and rooted in the plots were measured for all plots. Cover was estimated to the 0.25% level using a plastic Mylar circle that was 0.5% of the 1m² area.

The stratified-random plot method was composed of 60 plots, 40 of which were 1 m² in size and 20 of which were 10 m² in size. These plots were stratified every 10 m along the 200m central transect and at random distances (within the boundaries of the plot and not overlapping the plots on the transect) perpendicular to the transect. Percent cover in all 1 m² plots was estimated as described in the systematic method.

The modified-Whittaker method included one large 1000 m² rectangular plot centrally located in the stand with one rectangular 100 m² plot, two circular 10 m² plots, and 10 circular 1 m² plots nested within the 1000 m² plot (Stohlgren et al. 1995, 1997; Yorks and Dabydeen 1998). (Note: The modified-Whittaker plot design is often altered to best meet the resources and objectives for a project). Percent cover as well as density of each tree seedling species rooted in the plot were estimated as in the previous two methods. If species were present in any of the nested plots, they were not counted again in the 1000 m² area.

The timed-meander method entails thoroughly walking each site for one hour noting the time every 10 minutes as new species are tallied (Goff et al. 1982). Because this is a plotless method, any variables based on plots can not be analyzed. This method samples 100% of each site.

Plot efficiency is important in any monitoring design- in general timed-meander methods are thought to take 30 minutes, the systematic method 1-2 hours, the random method 2-4 hours, and the modified-Whittaker 2-3 hours (for two botanists to complete). Sampling time includes plot set up (Hunter et al. 2006, Freeman et al. 2008).

Huebner (2007) found that the timed-meander method and, to a lesser extent, the random method resulted in the highest estimates of species and, thus, best defined the flora and invasive exotic species of each site for herbs, vines, shrubs, and tree seedlings. The timed-meander method detects more species of all species categories than any other method, but it still failed to detect some species of sedge and grass. The timed-meander method is also limited in its ability to detect changes in species abundance and their relative importance because of its reliance on presence-absence data. Furthermore the time meander method is also dependant on the skill of the botanist so results could vary widely. The modified-Whittaker plot failed to detect a large number of species, thought to be an artifact of its central design (Huebner 2007). It was also time consuming to set up and complete. The random method's detected a large amount of species relative to other methods which is often attributed to its greater sampling intensity (Palmer et al. 1995).

Many researchers support the use of variable plot sizes in order to maximize species detection (Barnett and Stohlgren 2003; Frischknecht 1981; Stohlgren et al. 1997). Smaller plot sizes are thought to be best suited to patches of vegetation that are relatively dense, while larger plots are more likely to detect species in widely spaced vegetation

(Chambers and Brown 1983; Mosley et al. 1989). Huebner's (2007) results support the use of variable plot sizes to increase intensity, instead of increasing the number of plots. Huebner's study (2007) found that the random method estimated species cover from a larger area than the systematic and modified-Whittaker methods, and it predicted more species than the systematic method. The modified-Whittaker method which is composed of multiple scales did comparatively well in estimating richness, but its abundance estimates and importance values are based on a much smaller sample area compared to the random method. Consequently, this method, which has been suggested as a standard sampling method (Barnett and Stohlgren 2003; Chong et al. 2001; Stohlgren et al. 1995, 1997), is considered by Huebner (2007) as unsuitable for some monitoring.

The author concludes that the random method came closer to defining true diversity, evenness, and species abundance. If the management goals of a site require only documentation of all species present and information on the relative abundance of such species is not important, the timed-meander method is the best of the four methods (Goff et al. 1982; Palmer 1995; Palmer et al. 1995). However, if abundance of a given species increases over time with a subsequent decrease in abundance of associated species, the random method will be the best of the four methods to capture this change (Huebner 2007). This approach is also recommended as part of the National Park Service (NPS) monitoring protocol.

In the NPS protocol, plots can be variable in size depending on the objective of the study and the vegetation type, but the recommended dimensions are 50m x 20m split into quarters (Figure 2). Herbaceous vegetation is measured using a point intercept approach, which is suitable for measuring relative and percent species cover by species over time. In areas with high shrub density a belt transect is recommended and should be measured along the point intercept transect. Woody debris and litter are recorded following similar protocol to the Brown transect method (Brown et al. 1982). Any shrub re-sprouts should be recorded and tallied. New seedlings are measured in a density plot and recorded only after the second year of survivorship. In high density areas the density plot can be sub-sampled and extrapolated for total density. Herbaceous layer species density is measured using a density sampling frame along the plot transects. Overstory tree data include measurements of diameter at breast height (DBH), crown position, crown description and diameter at root crown and are carried out on the entire plot area.

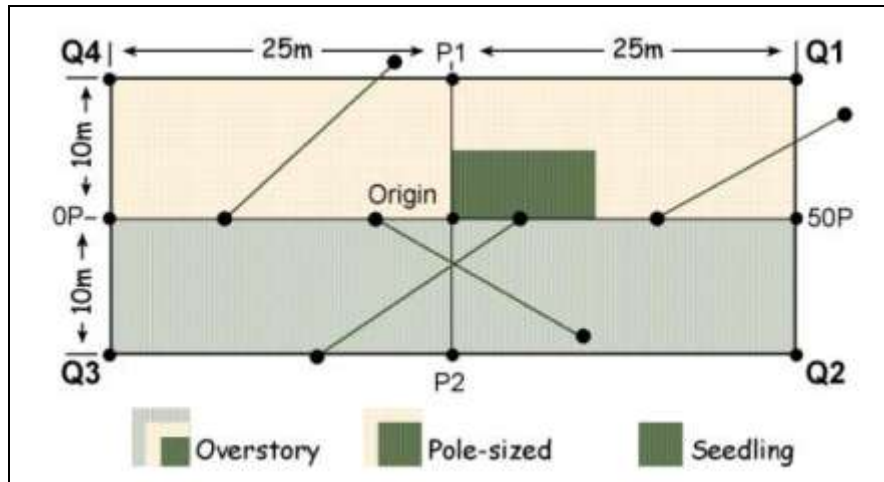

Figure 2. The NPS protocol plot design

Keyser et al. 2008, assessed ponderosa pine regeneration following a mixed severity fire in the Black Hills utilizing a randomly generated plot approach similar to the NPS protocol. Within each regeneration plot, the number of seedlings less than 1.4 m in height was enumerated. To determine whether seedlings germinated postfire or were fire survivors, each seedling was aged by back-counting the bud scale scars from current year growth. Only seedlings that germinated postfire were counted and included in the analysis.

The FIA plot design utilizes 3 transects in a Y shape, along which square plots are erected for carrying out percent cover and species composition counts. Transect lines have been utilized by a number of researchers as a means to decrease plot set up times and thereby increase efficiency. The Forest Service Region 3 fire monitoring protocol is in the process of being designed to use a similar transect approach. Ffolliott et al. (2000) carried out systematic sampling of understory response using permanent sampling plots located at regular intervals along a series of transect lines. Transect lines were orientated to maximize the variability in measurements on sample points along the lines. The author used approximately 200 sampling points. Plot understories were monitored using point sampling techniques and a basal area factor of 25 was used to select tally trees. Stocking of small trees were used to estimate stand density and change over time.

Diaz-Delgado et al. (2003) took a different approach to assessing plant response to fire. They looked at consumption of fine branches on woody plants classifying damage into 7 classes based on the degree of consumption. This methodology is only really suitable where fire effects are easily differentiated into classes; in some vegetation (for example piñon-juniper) fire doesn't produce such a refined scale of damage.

BURN SEVERITY/ FUELS

Burn severity is a nebulous term with numerous definitions in the literature (Wang 2002; Wells et al. 1979; Chappell and Agee 1996; FIREMON 2003); the most widely accepted

definition is that of Ryan and Noste (1983) who suggest that burn severity should be a combination of soil and overstory effects- "fire effects that incorporate both upward (fireline intensity) and downward (heat-per-unit-area) heat pulses." Therefore the most damaging fire is not always those that consume overstory trees but also burns that damage underlying duff and forest floor; deep charring of the ground surface may cause numerous species to be lost from the site (Ryan and Noste 1983). The Ryan and Noste definition is readily adopted by researchers and agencies and incorporates parameters that are easily measured in the field.

The attributes of burn severity as defined by Ryan and Noste (1983) can be measured through assessment of scorch height and ground char depth. Using this definition Omi and Martinson (2002) in a study of fuels treatments, evaluated fire severity in terms of stand damage – percent scorch, and percent consumption throughout the sample plot, and downward heat pulse- existence of unburned litter and duff and changes to mineral soil color and texture. Omi and Martinson (2002) utilized a modified-Whittaker plot design (Stohlgren 1997) measuring ground char on 10 1m² subplots and stand damage on a variable radius based on basal area. Tree height, DBH, position, height to pre fire live crown, highest scorched needle, highest point of bole char, percent canopy scorch, and percent canopy consumed are measured.

The modified-Whittaker plot design has been adopted in a number of burn severity studies (Omi and Kalabokidis 1991; Cram et al. 2006; Freeman et al. 2008; Hunter et al. 2006). Adjustments have been made to the original proposed size and shape of the plot and subplots (Stohlgren 1997) in order to reduce time for monitoring (Freeman et al. 2008). The Ryan and Noste protocol has also been implemented and adapted on variable radius plots (Cram et al. 2006). Surface damage parameters were adapted from Ryan and Noste (1983) (table 1) and crown damage followed Omi and Kalabokidis (1991) criteria (table 2). Most studies that include ocular estimates task these measurements to one researcher in order to remain consistent throughout the study.

Table 1. Ocular estimates of surface damage following wildfire (Source: Cram et al. 2006 - adapted from Ryan and Noste 1983)

Unburned- 0	The fire did not burn on the forest floor. Some damage may occur due to radiated heat from adjacent areas.
Light surface char-1	Leaf litter charred or consumed. Surface appears black immediately after fire. Upper duff may be charred. Woody debris partially burned. Some small twigs and much of the branch wood remain. Logs scorched or blackened but not charred.
Moderate surface char- 2	Litter consumed. Duff deeply charred, but mineral soil not visibly altered. Light-colored ash immediately after fire. Woody debris largely consumed. Some branch wood remains, but no foliage or twigs remain. Logs deeply charred.
Deep surface char- 3	Litter and duff completely consumed; mineral soil visible. Structure of surface soil may be altered. Twigs and small branches are completely consumed. Few large branches may remain, but deeply charred. Sound logs deeply charred; rotten logs completely consumed.

Table 2. Ocular estimates of crown damage following wildfire (Source: Cram et al. 2006- adapted from Omi and Kalabokidis 1991)

Unburned- 0	Fire did not enter stand.
Light- 1	Surface burn without crown scorch.
Spotty- 2	Irregular crown scorch.
Moderate- 3	Intense burn with complete crown scorch.
Severe- 4	High intensity canopy burn with crowns totally consumed.

Battaglia et al. (in press) also assessed severity based on basal charring of each tree in their overstory plots, hypothesizing that cambial damage can impact long term tree survival. Severity was rated from 0-3 based on classification developed by Ryan (1982). Moderate and deep basal charring is thought to be sufficient to kill the cambium and therefore increase tree mortality post fire (Thies et al. 2006).

In 1999 Key and Benson developed a new severity index and burn monitoring protocol termed the Composite Burn Index (CBI). This protocol became part of the FIREMON protocol for measuring fire effects. The CBI adopts a multi-strata approach (including small trees and shrubs) to monitoring burn severity, differing from the Ryan and Noste (1983) approach of only a two strata assessment. The CBI approach breaks plot vegetation down into Understory vegetation- substrates, herbs, low shrubs, small trees, tall shrubs and sapling trees, and Overstory- Intermediate pole sized trees (subcanopy) and big trees (mature dominant canopy). Each strata is rated in terms of the degree of damage- %green (unburned), % black (torched), % brown (scorched/girdled) and % canopy mortality. Substrate damage is measured in terms of scorching and consumption of litter and duff, consumption of fine and heavy fuels and changes to soil color and cover. The CBI plot design and protocol have been tested throughout the country and have proven to be a fast and efficient way of monitoring burn severity (Freeman et al. 2008; Cocke et al. 2005).

CBI plots are also designed for ground truthing satellite classification of burn severity and have been tested against other protocol. Cocke et al. 2005 compared Normalized Burn Ratio (Landsat derived satellite classification of burn severity) and CBI plots- They

used the NBR classification to select plots stratified by burn severity- low-extreme. Key and Benson (1999) recommend sampling 20-40 plots per severity type. Some researchers have adapted the CBI plot to also include measured parameters such as fuels (Freeman et al. 2008; Cocke et al. 2005). Cocke et al. (2005) also carried tree measurements including tree species, DBH, height and condition. Seedling trees (those below 2.5 cm DBH) were tallied by species, condition and height class in a 50m² subplot. Understory vegetation cover and tree canopy cover were sampled along point-line intercept transects. Forest floor and woody debris were measured along 4 16m planar intersect transects (Brown et al. 1982). Fuels were recorded by 1-100hr fuel particle size and duff depths were measured at intervals along each transect line. Post fire measurements were monitored using the National Park Service protocol- tree condition class, char height, scorch percent.

WOODY DEBRIS AND FUELS

Varying levels of fire severity can affect the structure and composition of the surface woody fuel bed, this has implications for vegetation response, erosion potential and wildlife habitat availability. After fire, there is often an immediate decrease in the abundance of both coarse woody debris (CWD) and fine woody debris (FWD) (woody biomass ≥ 7.6 cm diameter) (Fule´ and Laughlin 2006). In ponderosa pine stands that experience high tree mortality, the decrease in surface fuels is short-lived as fire-killed snags quickly transition from the canopy to the surface fuel bed (Passovoy and Fule´ 2006). A number of authors have studied tree mortality and woody debris in ponderosa pine stands burned under varying fire severities (Keyser et al. 2008; Battaglia et al. in press; Freeman et al. 2008)

Keyser et al. (2008) quantified the effects of wildfire on the forest floor by measuring litter and duff depth and surface woody fuel biomass. Litter and duff depths were measured every 2 m along a 60-m transect. Litter was measured annually in order to determine a yearly site average. Both FWD (Mg/ha) and CWD (Mg/ha) were sampled at each site using the planar intersect method (Brown et al. 1982). Fine fuels were measured along 10 m of the 60-m transect and coarse fuels were measured along the entire transect. Browns transects are the most commonly applied approach for quantifying coarse woody debris and fuels.

A well utilized approach is to establish permanent study sites in burned and unburned stands, with replicates in each fire severity class. Plots can often be assigned based on estimates of crown and forest floor damage from aerial photographs. Measurements include: tagging all trees over 1.4 m in height, recording species and tree mortality, and measuring DBH (diameter at 1.4 m above the soil surface), tree height (m), and the prefire height to the base of the live crown (m). On each tagged tree, crown and stem damage should be measured (Keyser et al. 2008) following burn severity protocol such as Ryan and Noste (1983) or Key and Benson (2003). Keyser et al. (2008), Lentile (2004) McHugh and Kolb (2003), Sieg et al. (2006) also monitor basal char, which serves as a proxy for cambial injury (which can girdle and subsequently kill a tree) and is measured as the percentage of the bole circumference charred below a height of 30 cm.

Claunch-Pinto SWCD has been working on a Collaborative Forest Restoration Project that assesses the ecological effects of thinning in the Cibola National Forest. Monitoring indicators and methods were developed using the guidance of the CFRP Monitoring Technical Assistance Team and Handbook 4: Monitoring Ecological Effects of CFRP projects (available on line at <http://www.fs.fed.us/r3/spf/cfrp/monitoring/>). The monitoring, which utilizes local high school children, includes measurements of adult tree size, density of saplings, Understory cover, Canopy cover, Surface fuels, and photo points. The study utilizes a 300 foot transect with varied plot sizes located at points along it. Tree measurements are made in 30 x 30 ft plots, while understory cover is measured in 3 x 3 ft plots. Surface fuels are measured along a conventional Browns transect, 30 ft in length.

TREE MORTALITY

Many authors have attempted to quantify tree mortality following wildfire. Studies have shown that in general, larger diameter ponderosa pine trees can survive proportionally greater crown damage than smaller trees (Stephens and Finney 2002; McHugh and Kolb 2003; Keyser *et al.* 2006; Sieg *et al.* 2006). The mortality thresholds are often dependent on tree diameter, bark thickness, pre-fire vigor, crown ratio, and the presence/absence of other fire-related injuries. Heating of the soil from surface fuel and forest floor consumption can also damage the fine root system (Smith *et al.* 2004; Hart *et al.* 2005) and contribute to tree mortality (Swezy and Agee 1991; Stephens and Finney 2002). Because root damage is inherently difficult to assess without excavation (Ryan 1982; Swezy and Agee 1991), the amount of charred ground is often used as a surrogate measure (Ryan and Noste 1985).

Battaglia *et al.* (In press) measured post-fire mortality of ponderosa pine seedlings and saplings on five dormant season prescribed fires. The authors use transects 200 m long with the direction of each randomly chosen. A plot (n=five per transect) was established every 50 m along each transect within a burn unit. A nested plot design with a 2 m radius circular plot to sample ponderosa pine seedlings (trees < 137 cm tall) and a larger 5m radius circular plot to sample saplings (tree 0.25 to 10 cm dbh) was used on all sites. The sapling plot radius was expanded where 5-m radius did not include enough saplings. Fire damage variables similar to those described by Keyser *et al.* (2008) were measured for each seedling and sapling on each plot.

The NMFWR have been working on a study of the impacts of the Ojo Peak fire that assess post burn severity and mortality. NMFWR are using a modified FFI/FIREMON sampling method that utilizes a 1/10 acre circular plot for measuring overstory trees and 1/100 acre plot for saplings. Surface fuels are also measured using a 75 ft Browns transect.

INVASIVE SPECIES

Large and severe wildfires can increase tree mortality, decrease grass cover and increase seed bank mortality. Following severe wildfire there is also high incidence of exposed bare soil and low tree canopy cover which increases the potential for non-native invasions (Wolfson *et al.* 2005; Hunter *et al.* 2006). Many burn areas are treated

with grass seed applications which can be controversial because mixes often contain non-native seeds (Robichaud et al. 2000). A number of studies have been carried out in recent years that assess the impact of fire on non-native species invasions.

Hunter et al. 2006 carried out a study to determine factors that relate to heavy infestation of invasives- i.e. soil fertility, disturbance severity, dominant native species cover, non-native species propagule pressure, native species richness. Sampling sites were selected randomly within the following strata- veg type, aspect, burn severity, post fire mitigation. Monitoring utilized the modified-Whittaker plot (Stohlgren et al. 1998) and similar studies of invasive species have adopted the same approach (Freeman et al. 2008; Omi and Martinson 2001). Burn severity was monitored following the Ryan and Noste (1985) methodology. Soil samples were taken from each corner and center of the plot. Soils were analyzed for carbon and nitrogen. Botanists identified and measured cover and height of all species in each 1m² subplot. The remainder of the plot is searched for any species not discovered in the sub-plots. Freeman et al. (2007) used a smaller version of the modified-Whittaker plot that has been found to be successful in capturing trends in dominant vegetation and environmental gradients (Barnett and Stohlgren 2003). Omi and Martinson (2001) also used the modified-Whittaker plot design to determine plant response and non-native species invasions. Vegetation data were grouped according to biotic predictor variables most likely to impact non-native species cover, i.e. cover of dominant native species (native grass cover), propagule pressure of non-native species through application of potentially contaminated seed mixes (seeded grass cover), and native species richness.

Huebner (2007) states that If the goal of a study is solely to detect the presence of invasive exotic species (or all species), the timed meander method (or a similar method) is most suitable. However, detection is rarely sufficient when evaluating success or failure of control strategies and management or impacts of invasion. Huebner considers the random method (or a method of similar intensity) to be the strongest for estimating changes in relative abundance. If significant changes in composition are suspected (i.e., after a disturbance or environmental stress event), it is advisable to use the timed-meander method periodically to assess the detection strength of the random method.

SOILS

Often wildfire disturbances result in increased nutrient availability, which is also shown to increase ecosystem invasibility (Stohlgren et al. 1999). Once established, invasive species may alter nutrient cycling, creating an environment more suitable to further invasion (Evans et al. 2001).

Many studies that assess vegetation response after burns involve an assessment of soil nutrient parameters. Hunter et al. 2006 and Freeman et al. 2008 both collected soil samples from the corners and center of the their modified-Whittaker plot design to determine the degree to which soil nutrients were influencing post fire species abundance. Soil samples were collected, air dried, sieved and ground using a standard roller mill. Soils were analyzed for percentage of total carbon and nitrogen using a LECO-1000 CHN analyzer (LECO Corporation, Saint Joseph, Missouri, USA) and

measured inorganic carbon using the modified pressure-calorimeter method (Sherrod et al. 2002).

WILDLIFE

A vast number of variables come into play when determining suitable wildlife habitat and this coupled with the unpredictable nature of fire and its effects on the landscape mean that determining how a species or group of species will respond to fire is an almost impossible task. Whelan (1995) suggests that the response of an animal to fire is likely to operate parallel to the reaction of vegetation due to the importance that vegetation has for habitat. Many researchers have followed this perspective and wildlife studies are often inferred from stand structure and species composition changes post fire. There has been a general lack of post fire monitoring of species, particularly those that are not deemed as game species such as deer and elk. Studies also tend to be biased towards easily monitored species such as birds and small mammals. Many studies of wildlife and fire make inferences based on fire effects on vegetation instead of direct species counts. This is often attributed to a lack of resources to monitor wildlife and logistical difficulties in long term monitoring of species. Fundamentally there is a funding need for greater monitoring of population changes across a range of species types (Baird et al. 1994).

Bock and Bock (1983) studied the response of birds and deer mice to fire in ponderosa pine forests in South Dakota where two controlled burns had occurred. Study plots were created prior to the burns, and vegetation cover transects were conducted pre and post burn. Surveys conducted two years after the fires showed a reduced litter-cover in the burn areas as well as a reduction in saplings. Breeding birds (7 songbird species were monitored) and deer mice were more abundant two years after the burn on the burn sites than the control plots. Small mammals are popular indicators of wildlife response to wildfire because of their ease of study and the fact that predator/prey inferences can often be made.

Converse et al. (2006) also studied small mammal response to fire in thinned versus unthinned stands. Habitat availability and species density of four small mammal species, deer mice (*Peromyscus maniculatus*), gray-collared chipmunks (*Tamias cinereicollis*), golden-mantled ground squirrels (*Spermophilus lateralis*), and Mexican woodrats (*Neotoma mexicana*) were studied. The study utilized mark-recapture techniques to assess population density. The results of the thinning and prescribed burn 2-3 years after the burn was an increase in herbaceous vegetation and decreased shrub density. Animal species were monitored relative to individual habitat traits, and a variety of relationships were discovered. For example, "deer mouse densities were negatively related to tree densities", and "Gray-collared chipmunks were negatively affected by treatment, negatively related to tree density, and positively related to woody debris" (Converse and White 2006). Brown transects were employed in determining density of woody debris.

Hobbs and Spowart (1984) studied nutrient content of foliage in mountain sheep and mule deer range following a burn in Colorado by taking cuttings of known forage species. The study found an increase in available protein for sheep and mule deer

during the winter for two years after prescribed fires in the Front Range of Colorado. The study found no change in protein availability during other periods of the year.

Randall Parker and Miller (2002) evaluated habitat availability in wildland areas. The study involved a catalog of wildlife habitat, primarily the availability of woody debris, primarily logs, snags, and oaks before and after five prescribed burns. The methodology "evolved from a variable plot method to a grid method through a series of sites" (Randall and Miller 2002). The final technique utilized the identification of all habitat items using aluminum tags. The findings state over 50% of all downed trees were consumed in the burns, and roughly 20% of all snags were burned.

Smucker et al. (2005) used a "before-after/control-impact (BACI)" (Smucker et al 2005) approach to study bird assemblages after a wildfire in the Bitterroot Mountains in 2000.

The methodology included the conduction of bird surveys every 10 minutes. Additionally vegetation surveys were used at 13 burn and 13 control sites. This data was available in the area before the fire, as well as after. The variance in vegetation density three years after the fire between burned and unburned areas was a function of burn severity. The abundance of nine birds species at sites was significantly different between the pre-burn and post-burn time frames at the burn sites. There was a strong variance in the post-burn habitats specific bird species would utilize.

Chambers and Mast (2005) studied the effects of fire on ponderosa pine snags. The study involved the creation of six, 1 hectare (2.5 acre) plots in Northern Arizona at recent fire sites. Six sites of the same size were created as control sites. Snags were mapped, and characterized. The results suggest the burned areas were characterized by a higher prevalence of snags and habitat cavities within ponderosa.

HYDROLOGIC RESPONSE & EROSION

Wildfire alters the hydrologic response of watersheds, including peak discharge resulting from rain events, transport of sediment, and rate of erosion and deposition (Moody 2001; Veenhuis 2002; Gallaher 2004; Martin and Moody 2001; Moody and Martin 2001a, Moody and Martin 2001b). Flooding and erosion following wildfires are a well recognized phenomena in montane areas of the western United States (Martin and Moody 2001). The removal of duff litter and the forest canopy along with the physical and chemical alteration of soil by fire change the erosional threshold of burned watersheds (Martin and Moody 2001). A relationship referred to as the rainfall-runoff relation indicates that a threshold of rainfall intensity exists, above which severe flash floods occur (Moody and Martin 2001b). Various methods of measuring these post-wildfire watershed changes have been practiced throughout the west.

Silt fences are considered an economical technique for measuring hillslope erosion (Robichaud 2002). Installing silt fences and tipping bucket rain gauges to measure onsite hillslope erosion provides a versatile method for measuring hillslope erosion in various settings (Robichaud 2002). Tipping buckets are a practical tool for measuring flow and is widely used in rain gauges (Black and Luce 2007). Black and Luce describe how to install and implement tipping bucket design for measuring plot discharge up to

35 gallons per minute. Also a system for measuring complete sediment budget for the plot, including necessary time and equipment is explained in the paper *Measuring Water and Sediment Discharge from a Bordered Road Plot using a Settling Basin and Tipping Bucket*.

A wide variety of methods have been used to quantify erosion after wildfires under natural conditions at different temporal and spatial scales. These methods can be grouped as: i) plot method; ii) silt fences; iii) reservoir trapping method; iv) suspended sediment method; and v) the erosion-pin method (Moody et al. 2007).

Volumes of eroded sediment after wildfires vary substantially throughout different geologic terrains across the western United States. These volumes are difficult to compare because they represent the response to rainstorms and runoff with different characteristics. By measuring the erosion response as the erodibility efficiency of water to detach and transport sediment on hillslopes and in channels, the erosion response from different geological terrains can be compared (Moody et al. 2007).

Numerous methods have been devised to directly and indirectly measure soil erosion due to water. Two field methods that are applicable to non-forested upland include an indirect measure of the change in elevation of the soil surface and a direct measure of the sediment produced from a defined area. Many other techniques have been developed that are highly sophisticated and are primarily suitable for research (Wirth and Pike 2007).

Digital data loggers are widely used for monitoring physical conditions in aquatic ecosystems (Dunham 2005). Protocols provided in *Measuring stream temperature with digital data loggers: a user's guide* demonstrate guidelines for selecting and programming data loggers, sampling water temperatures in the field, data screening, analysis, and data archiving (Dunham 2005).

WATER QUALITY

Increased storm runoff and transport of contaminants by runoff after a wildfire raises concerns about water quality (Gallaher 2004). After the Cerro Grande, runoff events were monitored and sampled throughout the summer runoff seasons of 2000 - 2003. Environmental samples of runoff and baseflow were compiled with the results of the Water Quality and Hydrology Group at Los Alamos National Labs and New Mexico Environment Department sampling to provide a comprehensive evaluation of the effects of the Cerro Grande on the environment (Gallaher 2004).

The labs use two types of sampling methods: automated sampling equipment and manual. After samples have been retrieved, they are sent to a DOE approved commercial analytical laboratory for analysis (Los Alamos National Laboratories 2007-2008).

After the wildfires experienced in southern California, the U.S. Geological Survey collected ash and burned soils from about 28 sites in the areas of southern California

affected by wildfires from November 2 - 9 2007. Researchers applied a variety of analytical methods to these samples to help identify characteristics of the ash and soils from wildland and suburban areas that may be of concern for their potential to adversely affect water quality, human health, endangered species and debris flow or flooding hazards (Plumlee et al. 2007).

EFFECTIVENESS OF RESTORATION

A white paper by Pyke et al. (2002) suggests that in the absence of intensive post-fire rehabilitation of native species, non-native species will out-compete many native plants, increasing fire risk and changing the age structure of the wildland area (Pike and McKinley). For example, the paper suggests a change is likely resulting in a move from perennial to annual plant species, reducing available winter habitat and food availability for animal species.

Monitoring the effectiveness of rehabilitation is important in determining which types of restoration strategies are successful. Recent reviews have found that existing data from monitoring and research at Emergency Stabilization and Rehabilitation (ES&R) and Burned Area Emergency Response (BAER) treatment areas are insufficient to evaluate the effects of the treatments. The purpose of the report *Monitoring Post-Fire Vegetation Rehabilitation Projects: A Common Approach for Non-Forested systems* is to i) document what monitoring methods are generally used by personnel in the field, ii) describe approaches and methods for post-fire vegetation and soil monitoring documented in agency manuals, iii) determine the common elements of monitoring program recommended in these manuals, and iv) describe a common monitoring approach to determined effectiveness of the future ES&R and BAER treatments in non-forested regions (Wirth and Pyke 2007).

Existing literature on treatment effectiveness is limited, thus making comparisons difficult. Contour felled logs, seeding, and reduction of road failures with treatments such as properly placed spaced rolling dips, water bars, and culvert relief to move water past the road prism and channel treatments are some of the methods discussed. Robichaud et al recommend increased treatment effectiveness monitoring at the hillslope and sub-catchment scale, streamlined postfire data collection needs, increased training on evaluation of postfire watershed conditions and development of an easily accessible knowledge base of BAER techniques (Robichaud 2000).

Evangelista et al 2004 monitored three burn sites in the Grand Staircase-Escalante National Monument which had received restoration treatments. One burn site along with its neighboring control site was treated with reseeding of native grasses, another pair of burn and non-burned sites was reseeded with non-native grasses and the final pair of sites were left to regenerate naturally. Burn sites regardless of treatment had high levels of non-native species encroachment. The study found that one particular non-native species, Cheatgrass (*Bromus tectorum*) was encroaching on all sites, providing a fire hazard for the future, which leads to an increase in probability of conditions favoring further non-native species proliferation, reducing native landcover and threatening juniper woodlands (Evangelista et al. 2004).

Wohlgemuth et al. 1998 evaluates the need for a more quantitative analysis of post-fire impacts on land cover and soil. Erosion was measured during the wet and dry seasons both before and after a burn. Unburned test plots were also monitored, serving as a control group. Erosion levels were aggregated over the season. Some plots were randomly reseeded with grasses after the fire. The results were unclear as the data recorded in this experiment could not be normalized. It is uncertain whether reseeding grasses had an impact on erosion rates. Reductions in erosion were significantly reduced with time; most sites saw a reduction in erosion to pre-fire levels within 2-4 years of the burn, though it should be noted the prescribed burn was described as less intense than recent wildfires in the surrounding area.

MONITORING PLAN

MONITORING OBJECTIVES

The broad objective of this post-fire monitoring study is to determine how wildfire affects Estancia Basin water recharge and water quality. Numerous environmental variables influence water yield and water quality, including soil parameters, and vegetation cover, structure and species composition. In order to quantify the impacts of these variables on hydrology, the fire monitoring study will incorporate monitoring of burn severity, vegetation response, non-native plant species invasion, and soil- erosion, infiltration, and stability. Wildlife habitat measurements and wildlife abundance measurements will also be made as an index to forest and watershed health. The monitoring will be carried out across 4 watersheds impacted by the Trigo fire. This scale of study enables us to determine the landscape level effects of the fire on watershed processes and water recharge.

SAMPLING/STUDY DESIGN

Locations

Sampling locations are stratified by: landownership (private land only), watershed, burn severity and existing monitoring study locations. Other variables that will be controlled for include- vegetation type, treatment history, soil type, geology, aspect, slope, and elevation. Plots are also selected based on access and distance from roads.

Because these plots are limited to private land on the eastern edge of the burn, the intent is to place plots in areas that can be compared to existing or future monitoring that is occurring in the upper watershed on USDA Forest Service land. Landscapes that exhibit the correct potential monitoring environments based on slope, aspect, and former forest vegetation type are shown in Figures 3 and 4.

Plots will be distributed randomly in four watersheds impacted by the fire. Within each watershed 2 plots will be located in high severity burn areas, 2 in low severity burn areas and 2 reference plots will be established in unburned areas. Exact plot locations will be randomly generated within available private land controlling for the variables listed above. Figure 5 illustrates the sampling design for the study.

A set of three wildlife cameras will be purchased and erected on one high, low and unburned study plot of the watershed. The cameras will be rotated between watersheds on a monthly basis, year-round.

Locations of hydrologic monitoring will be as close to the monitoring plots as possible. The proximity of the hydrologic monitoring relation to the plots will be a function of the exact location of monitoring sites. During the final site selection phase, the proposed sites will be mapped using GPS technology.

Study Plot Design

The study plot design is based upon a number of existing monitoring protocols including the NFWRI monitoring design, the USFS Forest Inventory Analysis plots and the USFS Region 3 monitoring protocol (in progress). This plot design was chosen because it is rigorous but also efficient, allowing a greater number of plots to be completed with the available resources.

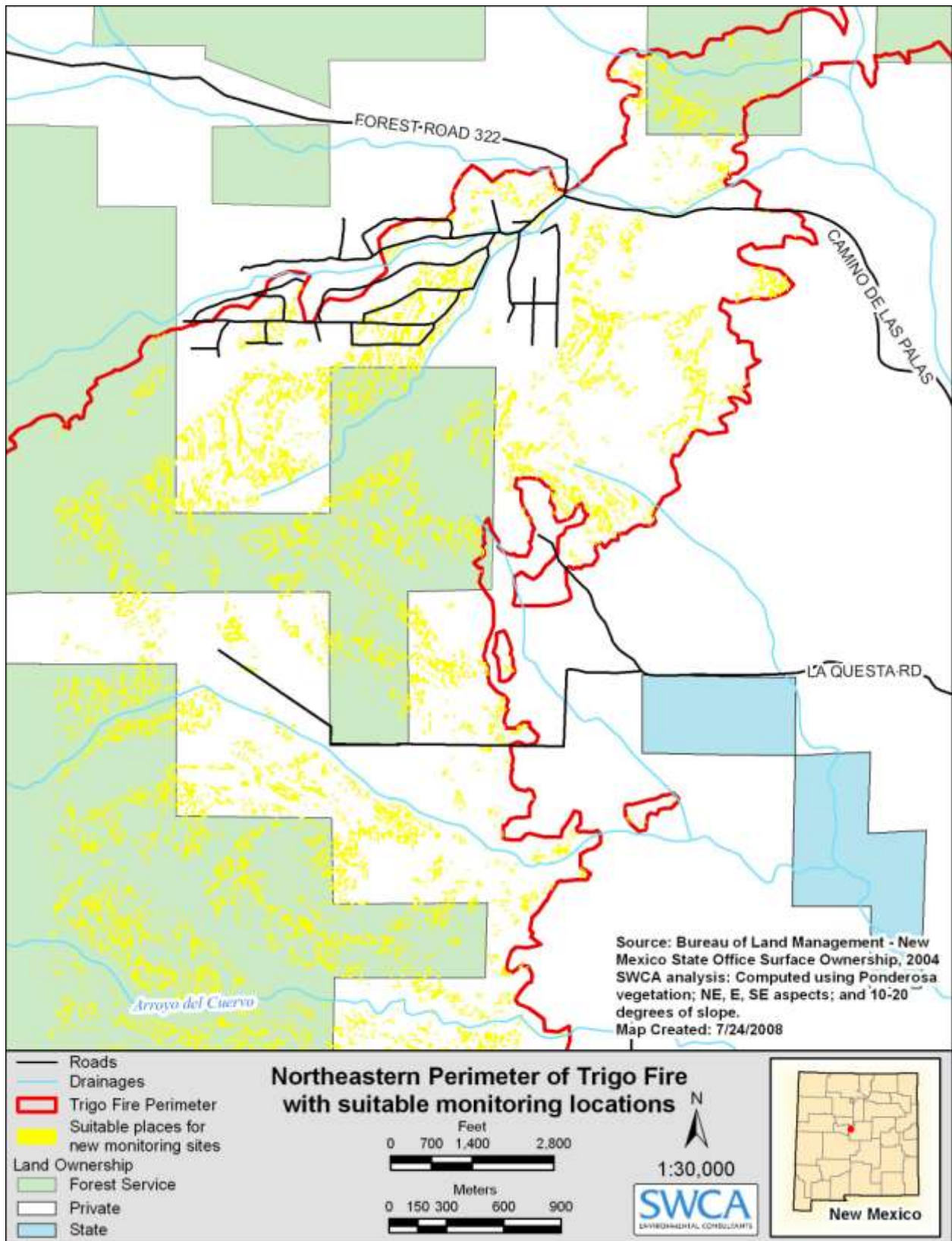

Figure 3: Northeastern Perimeter of Trigo Fire with suitable monitoring sites.

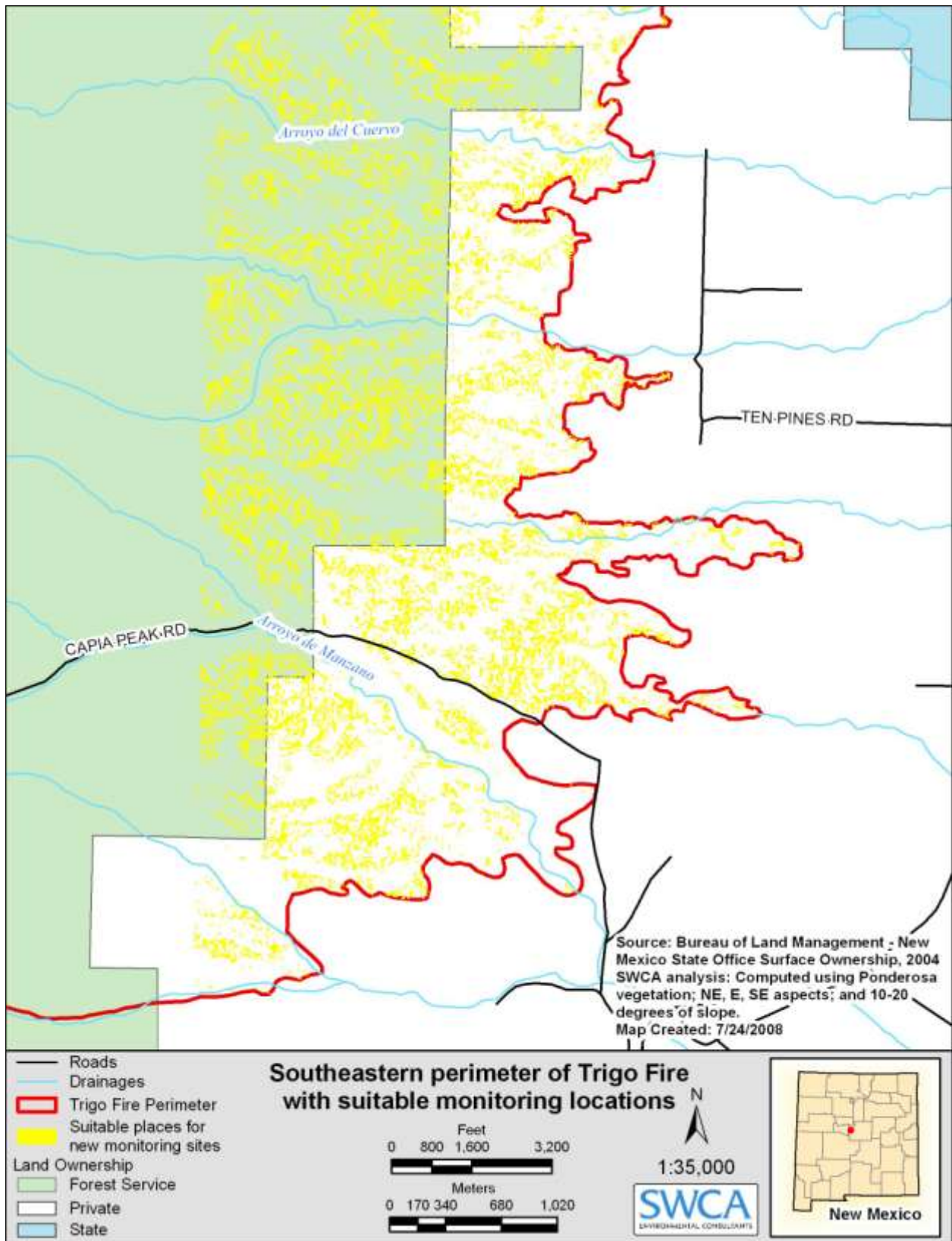

Figure 4: Southeastern Perimeter of Trigo Fire with suitable monitoring sites

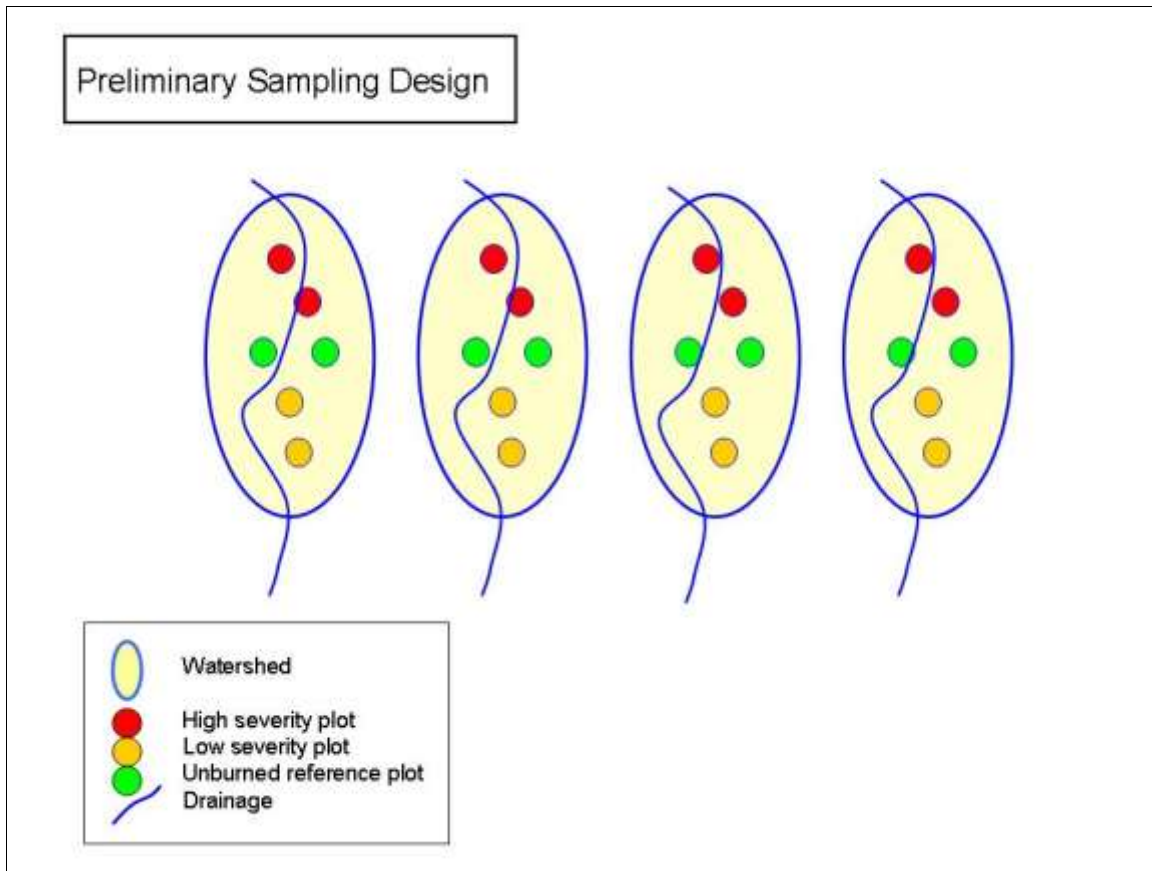

Figure 5. Sampling Design. Note, this diagram is schematic, actual plots representing treatment types will be intermixed on the landscape in each watershed, not grouped together as in diagram.

Study Plot Installation

All study plots will be installed prior to monitoring and marked using a T-post at the center and rebar at the end of each transect line. The plot center will be recorded with Geographic Positioning System (GPS) Coordinates in order to allow future navigation to the site. Plots will be labeled using aluminum tags.

Each study plot will be composed of four 75ft (22.9m) transects in each cardinal direction (figure 6). Along each transect, vegetation line intercept measurements will be made to determine species composition and cover of understory species. Two 1m² subplots will be located along each transect at the 25 ft and 50ft marks. These quadrants will be used to measure species composition, percent cover and understory fire severity (litter/duff consumption and soil changes). One Browns fire fuel transect will be completed on a random azimuth. The azimuth will then marked and staked for future fire fuels monitoring.

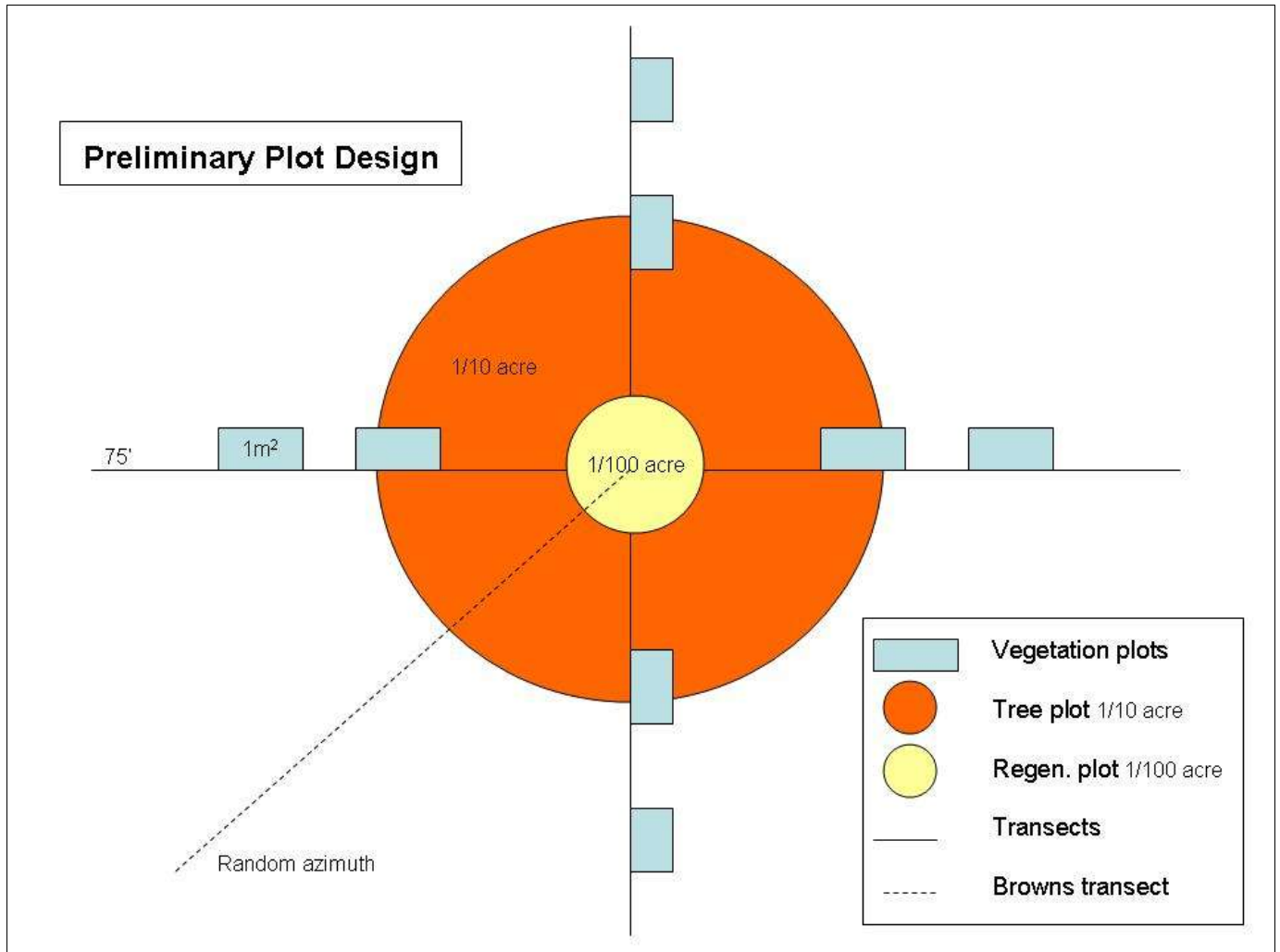

Figure 6. Proposed study plot design.

Plot Description

Each plot will be given a plot number that will be recorded on the data forms and labeled in the center of the plot on an aluminum tag. Plot coordinates, elevation, slope and aspect will be recorded on data forms prior to monitoring.

Digital photos (6mp) will be taken from the plot center in each cardinal direction. A white board with plot number will be placed in each picture. The photos should also encompass the general landscape to identify edge effects. One photo will also be taken along the fuels transect.

MONITORING PARAMETERS

Automated rain gauges with data loggers, including ambient and soil temperature, and soil moisture (-10cm) will be installed on one of the two replicate plots representing high burn severity, low, and unburned reference, in association with each group of plots

in each water shed. Graduated cylinder rain gauges will be installed at the other plot representing each treatment type plot pair, and readings taken monthly. Placing automated rain gauges at only one of the two plots representing each pair will be done simply to reduce costs. Soil moisture and temperature readings will be taken monthly on each plot with portable TDR and temperature probes. Most of these parameters will be measured monthly by either SWCA or CPSWCD field technicians. The proposed parameters to be measured include:

Rainfall, Soils and Hydrology

- Precipitation
- Precipitation/soil Infiltration Rate
- Soil Erosion/Sediment Load
- Suspended Sediment Load, Nutrients
- Total Sediment Load
- Runoff Salinity
- Temperature
- Groundwater Recharge
- Flow Duration
- Flow Stage
- Flow Flashiness
- Soil Temperature
- Soil Moisture
- Sodium
- Soil Nitrogen (NO₃)
- Phosphorous
- Potassium
- Soil Stability
- Soil Surface Erosion
- Soil Surface Stability

Vegetation

Vegetation monitoring will occur within each plot and will be measured bi-annually. The proposed parameters to be measured include:

- Growth form and life-history composition
- Species composition
- Species density
- Percent cover by cover class- grass, forb, shrub, tree
- Density of invasive species
- Canopy cover
- Stand structure
- Fuel loading
- Understory burn severity
- Overstory burn severity

Wildlife

Wildlife species (ground squirrel sized and larger) abundance's will be recorded within each watershed and each burn severity type by use of stationary infrared cameras, and track and scat counts on vegetation quads and lines. Wildlife habitat also will be assessed based upon the vegetation and fire fuels measurements. The proposed parameters to be measured include:

- Species abundance/presence
- Wildlife habitat- based on vegetation and coarse woody debris measurements

METRICS

Consistency in data collection is paramount. Each member of the field crew will be trained on proper use and maintenance of each measurement device. They will also be instructed on the units in which data shall be recorded. Parameters will be monitored by measuring the following metrics:

Plot Description

- Plot number
- Coordinates of center and end point of each transect
- Azimuth of fuels transect
- Elevation
- Slope
- Aspect

Rainfall and Hydrology

- Runoff flow (cubic feet per second)
- Piezometers (mm Hg)
- Stage Height (inches)
- Total Suspended Solids (mg/liter)
- Turbidity (Nephelometric Turbidity Units)
- Bed load

Soil

- Rainfall (mm)
- Temperature (Celsius)
- Piezometers (mm Hg)
- Sodium (parts per million)
- Nitrogen (parts per million)
- Potassium (parts per million)
- Phosphorus (parts per million)

Vegetation

Understory

- Species type
- Species density
- Plant height
- Species percent cover
- Invasive species count

Overstory

- Species
- Tree count
- Tree status- live/dead
- Height
- Crown Base Height
- Crown ratio
- DBH
- DRC
- Crown position
- Damage rating – snag class

Severity Measurements

- Understory: litter consumption, duff consumption, ground char, soil color, ocular severity rating: Ryan and Noste (1983) severity classification (table 1).
- Overstory: crown scorch, crown consumption, char height, bole char, height to pre fire live crown, scorch height, Ocular severity rating: Omi and Kalabokidis (1991) severity classification (table 2).

Wildlife Habitat

Track and scat

- Species ID

Presence- infra red camera

- Species ID

HYDROLOGIC MONITORING

In order to quantify fire effects on water yield and recharge to the Estancia Basin we will be carrying out monitoring of a number of hydrologic parameters. These include:

- Manual collection of water quality samples in downstream washes
- Monitoring of shallow groundwater levels using piezometers
- Surface stage and water quality measurements

- Stock tank monitoring

Monitoring at research sites

Periodic infiltration measurements will be determined using a double-ring infiltrometer located at each vegetation plot. Infiltration will also be monitored using nested soil moisture probes. Because there is potential for significant erosion on burned sites, soil erosion and sediment load will be quantified using silt fence plots and erosion bridges located within or adjacent to vegetation plots. Suspended sediment load and nutrient load will also be determined using manual samplers.

Piezometers and stream stage monitoring

Piezometers will be installed in major drainages that drain each site in order to monitor shallow groundwater. Instrument piezometer with Troll or multi-parameter probes will be used to measure water level, temperature, and total dissolved solids (TDS).

To quantify flow duration, flow stage, and flow flashiness, surface monitoring points will be installed with turbidity or other available water quality sensors.

NOTE: This approach can not be used to determine real flow rate measurement, only stage. This will not quantify any increases in flow coming off of burned watersheds.

Water Quality Sampling

Arroyo Water Samples

When a flow event happens, technicians will collect water samples to assess total sediment load and nutrient load; parameters measured will include suspended sediment, bed load, and water quality parameters (nutrients, cations/anions, organic load, TDS). Flow events will be monitored manually from a suitable location (e.g. bridge). A portable nutrient sampling device will be used to analyze samples.

Stock Tank Survey

If possible we propose identifying the nearest downstream stock tank from the burn site on each wash. This could be used to establish a benchmark and conduct baseline topographic survey to determine volume of each stock tank.

Periodic (quarterly) topographic surveys would be carried out to determine the volume and estimate sediment load of wash. In addition water quality will be monitored.

SOIL

Data collection will use a rigorous methodology that will be standardized for all sample sites. All data collection efforts will follow the standard site-specific methodologies including staying on fixed paths within the site to reduce soil disturbance.

Rainfall will be recorded in hourly intervals automatically, no manual data collection is necessary. The data will be downloaded from the data logger every 3 months, and will be integrated into the data set.

Soil Temperature

Soil temperature also is important to plant survival and growth, and affects soil water content by affecting evaporation and plant root uptake. Soil temperature also may change as a result of forest thinning because of reduced forest canopy cover and increased insulation. Portable, 10 cm digital soil moisture temperature probes will be used to measure soil temperature at 10 cm below the soil surface at the same locations and at the same times that soil moisture is measured as described above. The permanently placed soil temperature probe associated with the rain gauge on one of each treatment study plots will provide continuous study site reference soil temperature data for depths of 10 cm below the soil surface, relative to the interval temperature data collected with the portable temperature probe. Temperature will also be recorded automatically. Like rainfall, the automatic data logger will be programmed to record hourly measurements, and like the rainfall gage, this instruments data logger will be downloaded every three months.

Soil Moisture

Soil moisture is critical to plant survival, growth, and species composition. Subsurface soil moisture varies as functions of surfacewater infiltration, soil particle water retention, and water loss through evaporation or uptake by plant roots. Input from infiltration and loss due to evaporation or plant uptake may change as a result of forest thinning resulting from soil disturbance and changes in plant canopy cover and composition.

We will use a portable time domain reflectometer (TDR) soil moisture meter to measure soil moisture on the study plots. TDR meters determine soil moisture by measuring the rate that an electromagnetic wave travels along a waveguide (the device rods) within the soil matrix. The speed of the wave through the soil is a function of the bulk dielectric permittivity of the soil, which in turn is a function of soil water content. The TDR converts dielectric permittivity to water content and provides a measure of soil volumetric water content. The TDR device is equipped with two 12 cm rods, which will be inserted to a depth of 12 cm into the soil at each measurement point. The TDR will provide an average water content of the soil for a cylinder of soil 9.3 cm across and 12 cm deep at each measurement point.

We will measure and monitor subsurface soil moisture and temperature from 12 systematically located points on each of the vegetation/soils monitoring plots. Each measurement point is located immediately outside of the outer-center of each of the small 0.5 × 2 m vegetation measurement subplots, four of which are in each corner of the three 30 × 10 m vegetation subplots. Measurements will be taken once every 2 months throughout the year, for a total of 6 readings each year (February, April, June, August, October, December), across the four seasons. The permanent soil moisture probe associated with the rain gauge on each study plot will provide continuous study

site reference soil moisture data for depths of 10–15 cm below the soil surface to relate to the TDR interval data.

Salinity

Salinity is important because high salinity levels can lead to reduction in native vegetation. Sodium will be measured monthly using a soil nutrient meter. This meter will measure sodium content in parts per million.

Macronutrients

Macronutrients are necessary for plant growth. A lack of one particular macronutrient can result in sub-optimal yields. Macronutrients will be measured using portable devices. These devices will be utilized to analyze samples collected in the middle of each of the four watersheds.

Soil Stability

The soil surface stability test developed by Herrick et al. (2005) provides information on soil texture, the extent of soil structural development and resistance to erosion, and the biological integrity of the surface organic matter and soil biota. Fire can cause short term impacts to soil stability and stability can decline if plant recovery is slow, due to the reduced fungal and litter inputs necessary for soil aggregate formation. Intense high severity fires can increase soil stability by making it hydrophobic. These surfaces however repel water increasing the potential for downslope erosion.

Soil surface stability reflects the presence of both abiotic and cryptobiotic surface crusts. The test measures the stability of the soil matrix when exposed to rapid wetting, such as occurs during intense rainfall. Unstable soil surfaces are prone to erosion when exposed to intense rainfall. Surface stability also indicates general stability of the soil surface when exposed to wind and other disturbances (Herrick et al. 2005). One sample point will be randomly located along each vegetation line, 1 m from and perpendicular to the line. The test will be repeated along the same lines, but not at the same points, once each year, during the dry season (May).

Soil Erosion

Soil surface erosion is an important aspect of watershed and forest health. Soil surface erosion will be measured by use of soil erosion bridges (Shakesby 1993) on each of the study plots. The erosion bridges are similar to those used by Shakesby (1993) and White and Loftin (2000) and consist of two permanent 0.5 inch diameter steel rebar support posts and a portable aluminum square pipe bridge with a series of pin-drop holes, and 1 cm diameter by 60 cm long aluminum rod drop pins. The steel pipe support posts are 1.2 m apart, and support a 1.2 m portable bridge approximately 30 cm above the initial soil surface. 20 pin-drop holes are distributed at 5 cm intervals along the bridge, for a horizontal measurement area of 100 cm (1 m) across the soil surface. Repeat measurements will be made from the permanently positioned top of the bridge to the

soil surface once each year in May. Silt fencing will also be used to measure the amount of sediment loss off of a given plot. The sediment will be retained in the fencing.

Soil Water Infiltration

Water infiltration into the soil surface is an important component of rainwater availability to vegetation and groundwater, in contrast to the destructive effects of surface runoff and erosion. Water infiltration will be measured at one randomly located point along each vegetation line, each at a point 1 m from and perpendicular to the line. Water infiltration will be measured using the single-ring infiltrometer methods described by Herrick et al. (2005) during the dry season (May).

VEGETATION MONITORING

Understory measurements

Understory vegetation measurement and monitoring protocols will follow the methods developed by Herrick et al. (2005). Two different methods will be used to characterize the plant species composition and foliage canopy profile up to 1 m above the ground surface- point line-intercept and 1 m² quadrats (positioned along each transect at 25 ft and 50ft). Gap line-intercept will be used to measure both plant canopy horizontal cover and soil surface cover, including bare soil, rocks, cryptobiotic crusts, leaf litter, and dead and down woody material. Point line-intercept data will provide height measures for all plants less than 1 m in height. Tree canopy measurements will provide heights for all plants greater than 1 m in height on the study plots. Plant heights will be measured once each year in September. Invasive species will be measured and documented in the same way as all other ground cover. Total plant species lists will be compiled from the line-intercept and quadrat data to provide species composition and diversity information.

In addition to the line intercept and quadrat data, we will visually survey each entire study plot to document all species, including those that may be outside of the vegetation measurement lines. A list of all plants including their growth-form (e.g., grasses, forbs, trees) and life histories (e.g., annual, perennial) will be constructed.

Plant canopy cover will be measured from the gap line-intercept transects and the 1m² quadrats to provide measures of plant cover by species, growth-form, life history, and total plant foliage cover. Plant canopy cover will be measured once each year at the end of the growing season in September, and monitored over time. As well as documenting native species the study will also focus on documenting non-native invasive species that may respond positively post fire.

Understory Burn Severity

Understory burn severity is measured in the 1m² quadrats. Measurements include assessing the percentage of the litter and the duff (in each quadrat) that is scorched or

charred, documenting the percent cover of mineral soil (areas where organic matter has been totally consumed) and documenting the soil color (to assess changes over time). An ocular estimate of burn severity of the ground surface (scaled from 0-3) will also be made for each 1m² sub-plot as well as in the entire plot area (area to the furthest extent of the understory transects). Estimates will be based upon the Ryan and Noste (1983) burn severity classification (Table 1).

Downed fuels

Protocol for the fuels transect measurements follow the NMFWR I Data Collection Field Guide. The fuels transect is 75ft long- a tally of 1hr (1/4 inch or less) and 10hr fuels (1inch or less) are taken at 15-21 ft, 100hr (3 inch or less) at 15-50 ft and 1000 hour (greater than 3 inch) at 15-75 ft. Duff and litter depth measurements are made at 45 ft and 75ft points along the transect. Fuel particles sizes are determined using the conventional go-no-go gauge (Figure 7).

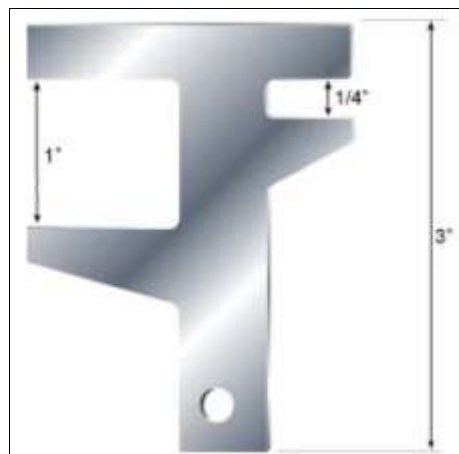

Figure 7. Go-no-go Gauge

Overstory Measurements

Overstory measurement protocols are developed from a number of sources- the NMFWR I protocols, the USDA Forest Service region 3 monitoring protocols (in press), USDA FIA protocols (2005), and protocols adapted from a number of peer reviewed authors [Ryan and Noste (1982), Battaglia et al. (in press), Omi and Kalabokidis (1991), Freeman et al. (2008)]. Overstory measurements are made to determine stand density, species composition, and fire effects such as percent crown scorch and tree mortality.

Overstory measurements are made in two circular fixed radius plots. Measurements on trees and snags (greater than 4.5ft) are made in a 1/10 acre (37.2ft radius) plot and measurements of regeneration and saplings (less than 4.5ft) are made in a 1/100 acre (11.8ft radius plot). Measurements should start from the north and continue in a clockwise direction. Measurements include: tree count, species, DBH, DRC, height (ft),

crown base height (ft), crown ratio (estimated percent of the total tree height that is occupied by live crown), crown position/class (dominant, co-dominant, intermediate, overtopped) and tree damage (insect kill, drought, lightning, missing top). The incidence of bark beetles, needle scales, spruce budworms, twig pruners, and pitch moths will be monitored on all conifer trees mapped and tagged on each of the study plots as an additional index of forest tree health. Presence of the bark beetle (wood dust/frass exuding from bark) and needle scales (dark scales on yellowing needles) and evidence of foliage mortality (pitch moths and twig borers) will be visually assessed each year when tree measurements are taken from the mapped/tagged trees on each of the subplots. Each tree will be scored on a scale of none (0), low (1–20%), moderate (21–50%), or high (>51%) incidence of insect occurrence (observable presence) and/or damage (observable tree tissue damage or senescence).

Canopy density is determined using a densiometer which will be read facing each cardinal direction from the center of the plot.

Overstory severity measurements are made in both circular plots on each individual tree). Severity measurements include: crown scorch (% of original crown), crown consumption (% of original crown), bole char (rating 1-5), char height (ft) and scorch height (ft).

Overstory Burn Severity

Overstory burn severity measurements will be made in the 1/100 acre and the 1/10 acre plots. Tree mortality will be noted of seedlings and saplings in the 1/100 acre plot. Severity measurements will be made in the 1/10 acre plots on all trees. Measurements include ocular assessment of percent crown consumption (percent of previous live crown where needles have been fully consumed), percent crown scorch (percent orange needles), char height (measured from ground surface to point of highest char height on the bole), bole char (Table 3-based on Ryan 1982) height to pre fire live crown (estimated height to lowest live needles) and scorch height (height to highest scorched needles). Heights will be measured using a digital hypsometer for accuracy and reduced measurement error.

Table 3. Basal Char Estimates: assessed on the first 5cm of the bole above the ground

0- unburned	
1- light	light scorch or char on the edges of the bark plates
2- moderate	bark is uniformly black with the possible exception of the inner depths of prominent fissures, but bark characteristics are still discernable.
3- deep	bark is deeply charred, but not necessarily to the wood and surface characteristics have been lost.

An ocular assessment will be made of the overstory burn severity in the entire plot area (area to the furthest extent of the understory transects) following the classification system derived by Omi and Kalabokidis (2001) (Table 2).

FIELD SAMPLING SCHEDULE

The measurable effects of wildfire on plants and soil surface characteristics will occur over long periods. For this reason this study project is initially proposed for a three year period but should be extended to 10 years based on available funding. Measurements will begin in September of 2008 and plots will be sampled during two field-sampling periods each year (September and May). Soil surface characteristics are best measured when surface soils are relatively dry, so those measurements will be taken during the typical dry season during the late spring and early summer, in May. Vegetation measurements will be taken in the spring and then again during the end of the typical growing season in late summer/early autumn, in September. Animals abundance (track and scat observations) will be measured at both times of the year to provide additional data to monitor changes in relative densities and species composition. Wildlife cameras will be in operation year round on a monthly rotation cycle between watersheds.

Field crews will be made up of at least 4 individuals in both spring and fall and survey periods are likely to be for 8-9 days. Plot set up will occur in mid August 2008 prior to the first round of monitoring. Monthly measurements of soil moisture and cycling of the wildlife cameras will be carried out by CPSWCD and Edgewood SWCD technicians. Care will be taken to avoid trampling of the plots, particularly along point line intercept transects and quadrants.

SAMPLING FREQUENCY

Plots will be sampled twice a year in the spring and fall. Hydrological measurements will be monitored monthly by either SWCA or CPSWCD technicians. Soil measurements will be taken monthly at the same time the hydrologic parameters are tested.

SAMPLING DURATION

Sampling will initially be carried out for three years with the intent to gain extra funding to sample over a ten year time period.

SCHEDULE

Trigo Fire Burn Monitoring by SWCA: Year One													
Project Task Description	Task	Date											
		July08	Aug08	Sep08	Oct08	Nov08	Dec08	Jan09	Feb09	Mar09	Apr09	May09	Jun09
Task 1: Literature Review and Monitoring Plan Development													
Literature search and compilation	001												
Plan Development	002												
<i>Error! Reference source not found.: Study Site Locations and Installations</i> <i>Error! Reference source not found.</i>													
GIS analysis of environmental variables	001												
Field verification	002												
Installation of vegetation plots	003												
Installation of hydrologic instruments	004												
Installation of soil instruments	005												
<i>Error! Reference source not found.: Initiate Monitoring Measurements</i>													
Vegetation	001												
Hydrology	002												
Soil	003												
Wildlife	004												
<i>Error! Reference source not found.: Compile Data and Analyze</i>													
Compilation of new data	001												
Quality control of data	002												
Summary Statistics	003												
<i>Error! Reference source not found.: Basin Watershed Health, Restoration and Monitoring</i>													
Post data analysis to SWCA ftp site	001												
Develop annual summary report	002												
Post annual report on NMFWR	003												

BUDGET

EQUIPMENT LIST

100m tape measure x 2
Stakes x 50
Quads x 10
Rangefinder/hypsometer x 1
Re-bar x 150
T-bar x 30
Go-No Go gage x 4
DBH tape x 2
Densimeter x 2
Meter ruler x 2
Rulers x 5
Sharpies x 5
Camera x 2
Compass x 2
Plant press x 1
Sample bags (soil) x 100
Pin flags x 100
Clinometer x 2
Hypsometer x 1
White Board x 2
PVC piping- 6 inch diameter
Soil erosion bridges x 96 (4 per plot)
Wildlife cameras x 3
Chair
Soil stability test kits x 2
Clip boards x 4
Weather stations including soil moisture, air temperature, soil moisture, and precipitation
x 12
TDR Soil Moisture Probe x1
Plant Nutrient Meter Nitrogen x 1
Plant Nutrient Meter Potassium x1
Plant Nutrient Meter Sodium x1
Plant Nutrient Meter Phosphorus x1
Flumes x 8
Piezometers x 4
Inverse Piezometers x 4
Level Trolls x ??

APPROVAL OF ESTIMATE AND NOTICE TO PROCEED

Dierdre Tarr, District Manager
Claunch-Pinto Soil and Water Conservation District

Date

Joseph Fluder III, Natural Resources Program Manager
SWCA Environmental Consultants

Date

REFERENCES

- Battaglia, M., F.W., Smith, W.D. Sheppard. In press. Predicting mortality of ponderosa pine regeneration after prescribed fire in the Black Hills, South Dakota, USA.
- Barnett, D.T., and T.J. Stohlgren. 2003. A nested-intensity design for surveying plant diversity. *Biodiversity and Conservation* 12:255-278.
- Black, Thomas A., and Charles Luce. Year? Measuring Water and Sediment from a Bordered Road Plot using a Settling Basin and Tipping Bucket. Rocky Mountain Research Station.
- Bock, C. E. and Bock, J.H. 1983. Responses of birds and deer mice to prescribed burning in Ponderosa Pine. *J. Wildl. Manage.* 47: 836-840.
- Brown, J.K., R.D. Oberheu, and C.M. Johnston. 1982. *Handbook for inventorying surface fuels and biomass in the interior West*. US For. Serv. Gen. Tech. Rep. GTR-INT-129. 22 p.
- Campbell, R.E.; Baker, M.B., Jr.; Ffolliott, P.F.; Larson, F.R.; Avery, C.C. 1977. Wildfire effects on a ponderosa pine ecosystem: an Arizona case study. Res. Pap. RM-RP-191. Fort Collins, CO: U.S. Department of Agriculture, Forest Service, Rocky Mountain Forest and Range Experiment Station. 12 p.
- Chambers, J.C., and R.W. Brown. 1983. Methods for vegetation sampling and analysis on revegetated mined lands, General Technical Report INT 151. Intermountain Forest and Range Experiment Station, USDA Forest Service, Ogden, UT. 57 pp.
- Chambers, C. and J. N. Mast. 2005. Ponderosa pine snag dynamics and cavity excavation following wildfire in northern Arizona. *Forest Ecology and Management*. Volume 216, September 2005.
- Chappell, C.B. and J.K. Agee. 1996. Fire severity and tree seedling establishment in *Abies Magnifica* Forests, Southern Cascades, Oregon. *Ecological Applications*. 6 (2) pp. 628-640
- Chong, G. W., Y. Otsuki, T. J. Stohlgren, D. Guenther, P. Evangelista, C. Villa, and A. Waters. 2006. Evaluating plant invasions from both habitat and species perspectives. *Western North American Naturalist* 66:92–105.
- Cocke, A.E., P.Z. Fule, and J.E. Crouse. 2005. Comparison of burn severity measurements using Differenced Normalized Burn Ratio and Ground Data. *International Journal of Wildland Fire*. 14. 198-198
- Converse, S.J., Block, W.M and White, G.C. 2006. Small mammal population and habitat responses to forest thinning and prescribed fire. *Forest Ecology and Management*. 228:263-273.

Covington W.W. and M.M.Moore. (1994) Southwestern ponderosa forest structure – changes since Euro-American settlement. *Journal of Forestry* 92, 39–47.

Cram, D.; Baker, T.; Boren, J. 2006. Wildland fire effects in silviculturally treated vs. untreated stands of New Mexico and Arizona. Research Paper RMRS-RP-55. Fort Collins, CO: U.S. Department of Agriculture, Forest Service, Rocky Mountain Research Station. 28 p.

Diaz-Delgado, R.,F. Lloret, and X. Pons. 2003. Influence of fire severity on plant regeneration by means of remote sensing imagery. *International Journal of Remote Sensing*, 24 (8) pp. 1751-1761.

Dunham, Jason; Chandler, Gwynne; Rieman, Bruce; Martin, Don. 2005. Measuring Stream Temperature with Digital Data Loggers: A User's Guide. Gen. Tech. Rep. RMRS-GTR-150WWW. Fort Collins, CO: U.S. Department of Agriculture, Forest Service, Rocky Mountain Research Station. 15 p.

Evangelista, P., Stohlgren, T. J., Guenther, D., Stewart, S. 2004. Vegetation response to fire and postburn seeding treatments in juniper woodlands of the Grand Staircase-Escalante National Monument, Utah. *Western North American Naturalist*, 2004 (Vol. 64) (No. 3) 293-305.

Evans, R. D., R. Rimer, L. Sperry, and J. Belnap. 2001. Exotic plant invasion alters nitrogen dynamics in an arid grassland. *Ecological Applications* 11:1301–1310.

Folliott, P.F., B. Malchus, Jr. Baker and G. J. Gottfried. 2000. Heavy thinning of Ponderosa Pine Stands: An Arizona Case Study. For. Serv. Research Paper. RMRS-RP-22. pp. 12.

FIREMON 2003. Fire Effects Monitoring and Inventory Protocol. Electronic version: <http://fire.org/firemon/> accessed July 6th 2008.

Freeman, J.P., T.J. Stohlgren, M.E. Hunter, P.N. Omi, E.J. Martinson, G.W. Chong and C.S. Brown. 2008. Rapid Assessment of Postfire Plant Invasions in Coniferous Forests of the western United States. *Ecological Applications*. 17 (6). 1656-1665.

Frischknecht, N.C. 1981. Double-frequency sampling for inventorying vegetation on salt desert shrub ranges. In H.G. Lund, M. Caballero, R.H. Hamre, R.S. Driscoll, W. Bonner (Eds.) *Arid land resource inventories: developing cost efficient methods*. General Technical Report WO-28. Department of Agriculture, Forest Service, Washington, DC. 435-440 pp

Fule PZ, Covington WW, Moore MM (1997) Determining reference conditions for ecosystem management of southwestern ponderosa pine forests. *Ecological Applications* 7, 895–908.

Gallaher, Bruce, and M., Richard J. Koch. September 2004. Cerro Grande Fire Impacts to Water Quality and Stream Flow Near Los Alamos National Laboratory. Results of Four Years of Monitoring.

- Herrick, J. E., J. W. Van Zee, K. M. Havstad, L. M. Burkett, and W. G. Whitford. 2005. Monitoring Manual for Grassland, Shrubland and Savanna Ecosystems. Quick Start. Design, Supplementary Methods and Interpretation, 1 and 2. USDA-ARS Jornada Experimental Range, Las Cruces, New Mexico. Tucson: University of Arizona Press. http://usda-ars.nmsu.edu/JER/Monit_Assess/monitoring_main.php (accessed July 2008)
- Hobbs, N.T. and Spowart, R.A. 1984. Effects of prescribed fire on nutrition of mountain sheep and mule deer during winter and spring. *Journal of Wildlife Management*, 48:551-560.
- Huebner, C. 2007. Detection and Monitoring of Invasive Exotic Plants: A Comparison of Four Sampling Methods. *Northeastern Naturalist*. 14 (20). 183-206
- Hunter, M. E., P. N. Omi, E. J. Martinson, and G. W. Chong. 2006. Establishment of non-native plant species after wildfires: effects of fuel treatments, abiotic and biotic factors, and postfire grass seeding treatments. *International Journal of Wildland Fire* 15:271–281.
- Key C. and N. Benson. 1999. The Composite Burn Index (CBI): Field Rating of Burn Severity. USGS NRMSC Research. <http://nrmsc.usgs.gov/research/cbi.htm>.
- Key, C. H., and N. C. Benson. 2005. Landscape assessment: ground measure of severity, the composite burn index; and remote sensing of severity, the normalized burn ratio. In D. C. Lutes, R. E. Keane, J. F. Caratti, C. H. Key, N. C. Benson, and L. J. Gangi, editors. FIREMON: fire effects monitoring and inventory system. General Technical Report RMRS-GTR-164-CD:LA1-LA51. USDA Forest Service, Rocky Mountain Research Station, Ogden, Utah, USA.
- Keyser T.L., F.W. Smith, L.B. Lentile, W.D. Shepperd. 2006 Modeling postfire mortality of ponderosa pine following a mixed-severity wildfire in the Black Hills: The role of tree morphology and direct fire effects. *Forest Science* 52, 530-539.
- Lentile (2004) LENTILE, L.B., F.W. SMITH., AND W.D. SHEPPERD. 2006. The influence of topography and forest structure on patterns of mixed-severity fire in ponderosa pine forests of the South Dakota Black Hills, USA. *Int. J. Wildl. Fire* 15:557–566.
- Lonsdale, W.M. 1999. Global patterns of plant invasions and the concept of invasibility. *Ecology* 80(5):1522-1536.
- Los Alamos National Laboratory. 2007-8. Available at: http://www.lanl.gov/environment/h2o/monitoring_faqs.shtml Accessed on 7/13/08/
- Martin, Deborah, A., and John A. Moody. 2001. The Flux and Particle Size Distribution of Sediment Collected in Hillslope Traps After a Colorado Wildfire. Proceedings of the Seventh Federal Interagency Sedimentation Conference, March 25 to 29, 2001, Reno, Nevada.
- MCHUGH, C.W., AND T.E. KOLB. 2003. Ponderosa pine mortality following fire in Northern Arizona. *Int. J. Wildl. Fire* 12:7–22.

Moody, John, A., and Deborah A. Martin. 2001a. Initial Hydrologic and Geomorphic Response Following a Wildfire in the Colorado Front Range. *Earth Surfaces and Landforms* 26, 1049-1070.

Moody, John, A. and Deborah A. Martin. 2001b. Post-fire, Rainfall Intensity-peak Discharge Relations for Three Mountainous Watersheds in the Western USA. *Hydrological Processes* 15, 2981-2993.

Moody, John, A. 2001. Sediment Transport Regimes After A Wildfire in Steep Mountainous Terrain. Proceedings of the Seventh Federal Interagency Sedimentation Conference, March 25 to 29, 2001, Reno, Nevada.

Moody, John, A., and Deborah A. Martin. Year? Hydrologic and Sedimentologic Response of Two Burned Watersheds in Colorado. U.S. Geological Survey. Water Resources Investigation Report 01-4122.

Moody, John, A., Deborah A. Martin, and Susan H. Cannon. May 2007. Post-wildfire Erosion Response in Two Geologic Terrains in the Western USA.

Mosley, J.C., S.C. Bunting, and M. Hironaka. 1989. Quadrat and sample sizes for frequency sampling mountain meadow vegetation. *Great Basin Naturalist* 49(2):241-248.

Omi and Martinson 2002 Omi, P.N.; Martinson, E.J. 2002. Effect of fuels treatment on wildfire severity. Final Report to Joint Fire Sciences Program Governing Board. Fort Collins, CO: Western Forest Fire Research Center, Colorado State University; 40 p.

Omi and Martinson 2004. Effectiveness and thinning and prescribed fire in reducing wildfire severity. USDA Forest Service Gen. Tech. Rep. PSW-GTR-193. 2004.

Omi, P.N.; Kalabokidis, K.D. 1991. Fire damage on extensively versus intensively managed forest stands within the North Fork fire, 1988. *Northwest Science* 65:149-157.

Palmer, M.W., G.L.Wade, and P. Neal. 1995. Standards for the writing of floras. *BioScience* 45(5):339-345

Plumlee, G.S., Martin, D.A., Hoefen, T., Kokaly, R., Hageman, P., Eckberg, A., Meeker, G.P., Adams, M., Anthony, M., and Lamothe, P.J., 2007, Preliminary Analytical Results for Ash and Burned Soils from the October 2007 Southern California Wildfires: U.S. Geological Survey Open-File Report 2007-1407.

Pyke, D. A. and R. A. McKinley. White Paper on Rehabilitation and Restoration. Third U.S. Geological Survey Wildland Fire-Science Workshop, Denver, Colorado, November 12-15, 2002. Summary Report, Appendix G. Available at: <http://pubs.usgs.gov/sir/2004/5005/> Last accessed: July 14, 2008

Randall-Parker, T. and R. Miller. 2002. Effects of Prescribed Fire in Ponderosa Pine on Key Wildlife Habitat Components: Preliminary Results and a Method for Monitoring. USDA Forest Service Gen. Tech. Rep. PSW-GTR-181. 2002.

Robichaud, Peter R.; Beyers, Jan L.; Neary, Daniel G. 2000. Evaluating the Effectiveness of Postfire Rehabilitation Treatments. Gen. Tech. Rep. RMRS-GTR-63. Fort Collins: U.S. Department of Agriculture, Forest Service, Rocky Mountain Research Station. 85 p.

Ryan, KC (1982) Techniques for assessing fire damage to trees. In: 'Proceedings of the symposium: fire its field effects.' (Ed. JE Lotan) pp. 2-10. (Intermountain Fire Council: Missoula, MT)

Ryan, K.C.; Noste, N.V. 1985. Evaluating prescribed fires. In: Lotan, J.E.; Kilgore, B.M.; Fischer, W.C.; Mutch, R.W. technical coordinators. Proceedings: symposium and workshop on wilderness fire; 1983 November 15–18; Missoula, MT. Gen. Tech. Rep. INT-182. Ogden, UT: U.S. Department of Agriculture, Forest Service, Intermountain Forest and Range Experiment Station: 230–238.

Ryan, K.C. and N.V. Noste. 1983. Evaluating Prescribed Fires. In: Proc. Of the Symp and workshop on Wilderness fire, Missoula, MT. Nov 15-18, 1983. USDA, For. Serv. Gen. Tech. Rep. INT-182, pp. 230-237.

Sherrad, L. A., G. Dunn, G. A. Peterson, and R. L. Kolberg. 2002. Inorganic carbon analysis by modified pressurecalcimeter method. *Soil Science Society of America Journal* 66:299–305.

Sieg *et al.* (2006), Sieg CH, Phillips BG, Moser LP. 2003. Exotic invasive plants. In *Ecological restoration of southwestern ponderosa pine forests'*. (Ed. P Friederici) pp. 251–267. (Island Press: Washington, DC).

Smith, J.K. editor. 2000. Wildland fire in ecosystems: effects of fire on fauna. Gen. Tech. Rep. RMRS-GTR-42-Vol. 1. Ogden, UT: U.S. Department of Agriculture, Forest Service, Rocky Mountain Research Station. 83 p.

Smucker, K.M., R. L. Hutto, and B. M. Steele. 2005. Changes in Bird Abundance After Wildfire: Importance of Fire Severity and Time Since Fire. *Ecological Applications* Vol. 15, No. 5.

Stephens S.L and M.A. Finney. 2002. Prescribed fire mortality of Sierra Nevada mixed conifer tree species: effects of crown damage and forest floor combustion. *Forest Ecology and Management* 162, 261-271.

Stohlgren, T.J., G.W. Chong, M.A. Kalkhan, and L.D. Schell. 1997a. Multiscale sampling of plant diversity: Effects of minimum mapping unit size. *Ecological Applications* 7(3): 1064-1074.

Stohlgren TJ, Bull KA, OtsukiY (1998) Comparison of rangeland vegetation sampling techniques in the central grasslands. *Journal of Range Management* 51, 164–172.

Stohlgren TJ, Binkley D, ChongGW, Kalkhan MA, Schell LD, Bull KA, tsukiY,NewmanG, Bashkin M, SonY(1999a) Exotic plant species invade hot spots of native plant diversity. *Ecological Monographs* 69, 25–46.

StohlgrenTJ, SchellLD,Vanden HeuvelB(1999b)Howgrazing and soil quality affect native and exotic plant diversity in a rocky mountain grassland. *Ecological Applications* 9, 45–64.

Swezy M.D and J.K Agee (1991) Prescribed-fire effects on fine-root and tree mortality in old growth ponderosa pine. *Canadian Journal of Forest Research* 21, 626-634.

Veenhuis, Jack, E., 2002. Effects of Wildfire on the Hydrology of Capulin and Rito de los Frijoles Canyons, Bandlier National Monument, New Mexico. U.S. Geological Survey. Water-Resources Investigations Report 02-4152

Wang, G.G. 2002. Fire severity in relation to canopy consumption within burned boreal mixed wood stands. *Forest Ecology and Management*. 163. pp- 85-92.

Wells, C.G. 1979. Effects of fire on soil: a state of knowledge review. U.S. Forest Serv. Gen. Tech. Report WO-7. 34pp.

Wirth, Troy A., and Pyke, David A., 2007, Monitoring Post-fire Vegetation Rehabilitation Projects—A Common Approach for Non-forested Ecosystems: U.S. Geological Survey Scientific Investigations Report 2006-5048, 36 p.

Wohlgemuth, P. M.; J.L. Beyers,, C.D. Wakeman and S.G. Conard, 1998. Effects of fire and grass seeding on soil erosion in Southern California chaparral. In: Proceedings, nineteenth annual forest vegetation management conference: wildfire rehabilitation, January 20-22, 1998. Redding, CA: Forest Vegetation Management Conference: 41-51.

Wolfson, B. A. S., T. E. Kolb, C. H. Sieg, and K. M. Clancy. 2005. Effects of postfire conditions on germination and seedling success of diffuse knapweed in northern Arizona. *Forest Ecology and Management* 216(1–3):342–358.

Yorks, T.E., and S. Dabydeen. 1998. Modification of the Whittaker sampling technique to assess plant diversity in forested natural areas. *Natural Areas Journal* 18(2):185-189.

Goff et al. 1982

APPENDIX A.
TRIGO FIRE POST-FIRE MONITORING MEETING MINUTES.

Informal Meeting to Discuss Manzano Mountains Post-Wildfire Monitoring

Meeting Minutes

Sponsored by SWCA Environmental Consultants
July 16, 2008. 10am

Introductions

- Attendees introduced themselves and their affiliations (sign in sheet attached):
 - Dave Lightfoot- SWCA
 - Joseph Fluder- SWCA
 - Victoria Williams- SWCA
 - Emily Geery- SWCA
 - Ryan Trollinger- SWCA
 - Pat Billig- SWCA
 - Dierdre Tarr- Claunch-Pinto SWCD
 - Pete Robichaud- Rocky Mountain Research Station
 - Joe Zebrowski- NM Forest and Watershed Restoration Institute
 - Mike Matush- NM Environment Department
 - Tedd Huffman- USFS- Cibola National Forest
 - Anne Tillery- USGS
 - Anne Marie Matherne- USGS
 - Karen Lightfoot- NM State Forestry
 - Susan Rich- NM State Forestry

Other programs/agencies objectives and approaches to Manzano Mountains post-fire monitoring.

Attendees briefly presented their Manzano Mountains post-fire monitoring projects; current/planned, sponsoring agency/organization, objectives, approaches, locations, duration, potential for collaboration, data sharing, etc.

Dave Lightfoot discussed that SWCA Environmental Consultants are currently working on a project to monitor the effects of forest thinning on forest and watershed health on privately owned forest lands in the Manzano Mountains. The project is funded by the State Water Trust Board, through the Estancia Basin Watershed Health, Restoration and Monitoring Committee (Claunch-Pinto, Edgewood, and East Torrance Soil and Water Conservation District offices, and the New Mexico Forest and Watershed Restoration Institute). He explained that this project has been extended to include monitoring of sites burned by the Trigo fire. Dave described the current monitoring objectives protocols that have been implemented for the project, which is directed toward water resources and impacts of forest thinning on hydrology, soils, vegetation, and animals.

Vicky Williams described the approach that SWCA would take for burn monitoring. The design is preliminary and the intent is to adopt a methodology that would ease data sharing amongst the interested parties. Vicky stated that the objective of the study is to determine impacts of the recent fires on watershed health and recharge into the Estancia Basin. She outlined the general focus of the study design- burn severity, vegetation response, wildlife response, soil erosion and hydrology. She also outlined environmental variables that should be considered in a sampling design – i.e. landownership, veg. type, soils, elevation, access, hydrology etc. The sampling design is yet to be determined but is likely to be dictated by landownership and access, location of other researcher's plots for data sharing, burn severity

and vegetation type. Vicky shared a preliminary plot design based off of the Forest Services (region 3) monitoring protocol and a literature review of recent burn monitoring studies. (preliminary plot design attached).

Emily Geery described the approach that SWCA may take for hydrological monitoring- discussing the use of gages and flumes. Emily would work with other interested parties to find a design that could enhance data sharing between agencies.

Pete Robichaud explained that the Rocky Mountain Research Station in conjunction with the Cibola National Forest are studying the effects of post-fire BAER treatments on the Trigo fire- straw mulch, seed only, seed and mulch combined.

The study includes erection of sediment fences to study hill slope erosion compared to control sites (areas with no treatments and areas outside of the burn). The group has also established raingages at each sediment fence and Pete is willing to share that data with others.

Anne Tillery and Anne Marie Matherne explained that the USGS study is more of a landscape scale study in which they have established stream gages and a network of rain gages.

Tedd Huffman described a study being implemented by Laura Kapiski looking at the same treatment sites currently being studied for Pete Robichaud. This study is looking at vegetation recovery on burned versus unburned control plots. Laura is also investigating effects of seeding treatments including analysis of seed mixes applied on the Ojo Peak, Trigo and Big Springs fires. (300 acres of seeding occurred in high severity areas of the Ojo Peak, 2,000 acres of seeding occurred in high severity areas of the Big Springs and 5,600 acres occurred in high and moderately burned areas of the Trigo). 10lbs per acre of seed were applied. They are also studying invasion by noxious weeds but will not be following a plot or sampling design just presence/absence in susceptible areas. The Cibola will also be studying effectiveness of seed germination on the Ojo Peak fire looking at presence/ absence of germinating seeds.

Mike Matush explained that he is available to assist with technical design of hydrology studies and provided recommendations on snow tails for snow measurements to deal with cold weather effects on regular tipping bucket rain gages.

Joe Zebrowski described a study that the NMFWRRI has partaken in with the Cibola National Forest looking at tree mortality following the Ojo Peak fire. The Institute established 30 plots in areas of low and moderate burn severity and measured fire effect parameters on 1/10 acre and 1/100 acre fixed radius plots. They classified surface fire effects into a 1-5 class rating. This project was to provide an initial assessment of burn severity.

Dierdre Tarr described a CFRP monitoring project that was impacted by the Ojo Peak fire but was initially looking at monitoring thinning effects. The project is organized through the Claunch-Pinto SWCD and involves Mountainair District school children for the monitoring. The project will continue to monitor burned areas and can compare data with pre fire measurements. The Claunch-Pinto SWCD are working with Ian Fox (Cibola NF CFRP coordinator) to gain more funding to extend the study.

Karen Lightfoot and Susan Rich explained that Mary Stuever also from NM State Forestry is establishing monitoring plots in Manzano State Park and will also be working with Albuquerque School District students to implement monitoring. They will be studying fire behavior and severity.

Coordination of post-fire monitoring projects?

The group discussed possible collaboration, data sharing, integration of studies/findings, potential for standardizing studies.

- The USGS are interested in a collaborative approach in order to extend their network of hydrological data for the burn. The USGS project is not funded at present and so they are eager to form a partnership with other researchers in order to leverage future funding. There is potential for SWCA to work with the USGS to combine efforts for the hydrology work. The USGS and other agencies present will discuss potential approaches to the hydrological work.
- Mike Matush is eager to be involved in study design of the hydrological monitoring for all those involved. Mike can act in a technical advisory role and would be available for plot set up.
- The group discussed data/information management, sharing and distribution. The NMFWRI will act as a clearing house for information management and data compilation and all data would be available through their website. When asked, no-one voiced concerns regarding data restrictions and sharing. The Institute is currently working with NM State Forestry in a joint powers agreement for a web based database of forest health data, this fire monitoring data would be added to this database.
- The NMFWRI would be interested in including in the database the soil moisture and precipitation data that has been collected by the Cibola and Pete Robichaud. The NMFWRI has already been working with SWCA and Claunch-Pinto to post data as part of the Estancia Basin monitoring project.
- SWCA is eager to work with all participants in order to gain information on watershed processes and fire effects higher up in the watershed on Forest Service lands. Vicky asked all participants to provide feedback on plot design and sampling for vegetation monitoring. Joe agreed to supply the NMFWRI monitoring protocol to SWCA.

Action Items

Task	Responsible Party	Time Frame
SWCA to coordinate with USGS regarding placement of gages and hydrological monitoring design	Emily, Anne and Anne Marie	By 7/31
SWCA to contact Mike Matush about technical methodologies	Emily, Dave and Mike	By 7/31
Dee to get report from Melissa Savage regarding CFRP monitoring and send to Vicky	Vicky and Dee	By 7/21
SWCA to finalize burn monitoring design	Vicky, Emily, Dave	By 7/30
SWCA to install burn monitoring plots	Vicky, Emily, Dave	By 8/22
Tedd to provide contact details for Laura Kapiski	Tedd	By 7/21